

2.0

RIDUTTORE AD ASSI ORTOGONALI

BEVEL HELICAL GEARBOX

KEGELSTIRNRADGETRIEBE

2.1	Caratteristiche	<i>Characteristics</i>	Merkmale	10
2.2	Designazione	<i>Designation</i>	Bezeichnung	11
2.3	Sensi di rotazione alberi	<i>Direction of shaft rotation</i>	Drehrichtungen der Wellen	12
2.4	Entrata supplementare	<i>Additional input</i>	Zusatzantrieb	12
2.5	Velocità in entrata	<i>Input speed</i>	Antriebsdrehzahl	13
2.6	Rendimento	<i>Efficiency</i>	Wirkungsgrad	13
2.7	Potenza termica	<i>Thermal power</i>	Thermische Leistung	13
2.8	Dati tecnici	<i>Technical data</i>	Technische Daten	14
2.9	Momenti d'inerzia	<i>Moments of inertia</i>	Trägheitsmoment	16
2.10	Dimensioni	<i>Dimensions</i>	Abmessungen	22
2.11	Accessori	<i>Accessories</i>	Zubehör	28
2.12	Giochi angolari	<i>Angular backlash</i>	Winkelspiel	33
2.13	Lubrificazione	<i>Lubrication</i>	Schmierung	33
2.14	Carichi radiali e assiali	<i>Radial and axial loads</i>	Radial- und Axialbelastungen	35
2.15	Lista parti di ricambio	<i>Spare parts list</i>	Ersatzteilliste	37

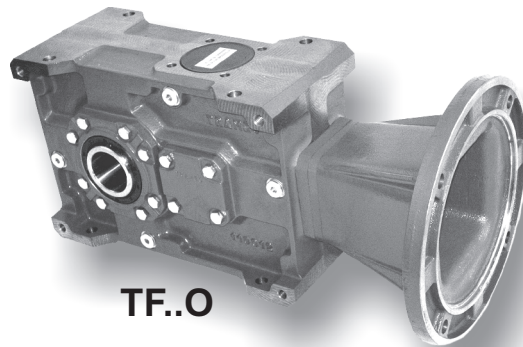

TF..O

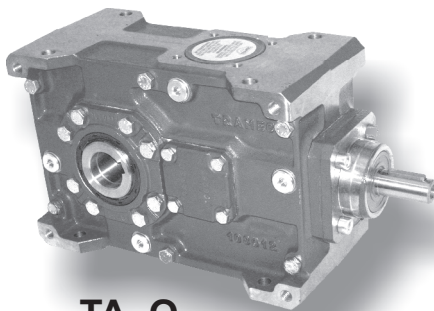

TA..O

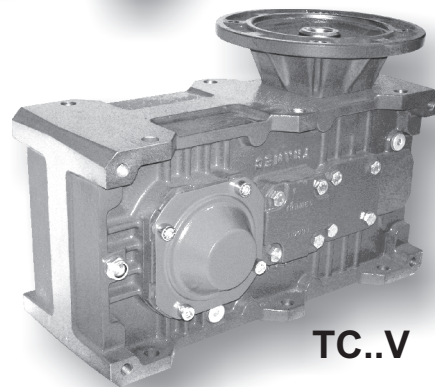

TC..V

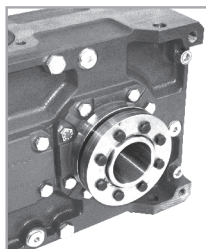

Albero lento cavo con calettatore
Hollow output shaft with shrink disc
Antriebshohlwelle mit Schrumpfscheibe

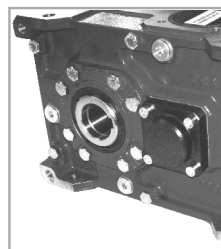

Dispositivo antiretro
Backstop device
Rücklaufsperr

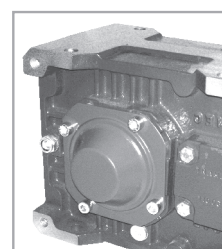

Kit protezione albero cavo
Hollow shaft protection kit
Schutzvorrichtung für die Hohlwelle

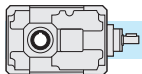

2.1 Caratteristiche

Costruiti in 9 grandezze a 2 riduzioni e in 8 grandezze a 3 riduzioni.

Sono previsti tre tipi di entrata: con albero entrata sporgente, con predisposizione attacco motore (campana e giunto) e predisposizione attacco motore COMPATTA, escluse grandezze 56 e 63. I tre tipi di entrata possono essere montati indifferentemente nelle esecuzioni verticale e/o orizzontale.

Il corpo riduttore in lega di alluminio, GAISi9Cu1 UNI7369/3 (56-63), in ghisa meccanica EN GJL 200 UNI EN 1561 (71-180) o in ghisa sferoidale EN GJS 400-15U UNI EN1563 (200-225), abbondantemente nervato all'interno e all'esterno per garantire la rigidità, è lavorato su tutti i piani per consentire un facile posizionamento; inoltre un'unica camera di lubrificazione garantisce una maggiore dissipazione termica e una migliore lubrificazione di tutti gli organi interni.

Gli ingranaggi sono costruiti in acciaio legato da cementazione e sottoposti a trattamento di cementazione a tempra. In particolare, la prima riduzione è costituita da due ingranaggi conici a dentatura spirooidale GLEASON con profilo accuratamente rodato, in acciaio 16CrNi4 o 18NiCrMo5 UNI7846 cementati e temprati.

L'utilizzo dei cuscinetti a rulli conici di qualità su tutti gli assi (ad eccezione del manicotto in entrata nella predisposizione attacco motore compatta, il quale è sostenuto da cuscinetti obliqui a sfere) consente al riduttore di ottenere delle durate molto elevate e di sopportare dei carichi radiali e assiali esterni molto elevati.

L'albero lento cavo di serie in acciaio (disponibile a richiesta con calettatore), la possibilità di montare una flangia uscita su uno o entrambi i fianchi laterali e la predisposizione per il montaggio del dispositivo antiritorno esaltano la versatilità di questi riduttori facilitandone l'installazione.

Il corpo riduttore, le flange, le campane ed i coperchi vengono verniciati esternamente di colore BLU RAL 5010, ad eccezione dei riduttori ortogonali delle grandezze 56 e 63, realizzati in alluminio.

2.1 Characteristics

Built in 9 sizes with 2 reduction stages and in 8 sizes with 3 reduction stages .

Three input types are available : projecting input shaft, pre-engineered motor coupling (bell and joint) and pre-engineered COMPACT motor coupling. (Sizes 56 and 63 excluded). the three input types can be mounted either vertically and/or horizontally.

Gear unit casing in aluminium alloy GAISi9Cu1 UNI7369/3 (56-63), in engineering cast iron, EN GJL 200 UNI EN 1561 (71-180) or spheroidal graphite cast iron EN GJS 400-15 U UNI EN 1563 (200-225), it is ribbed internally and externally to guarantee rigidity. It is machined on all surfaces for easy positioning. The single lubrication chamber guarantees improved heat dissipation and improved lubrication of all the internal components.

Gears are built in casehardened compound steel and have undergone case-hardening and quench-hardening treatments. In particular, the first reduction stage consists of two GLEASON spiral bevel gears with precision ground profile, in 16CrNi4 or 18NiCrMo5 UNI7846 case-hardened and quench-hardened steel.

The use of high-quality tapered roller bearings on all shafts (except for the input sleeve on the pre-engineered compact motor coupling, which is supported by angular ball bearings) ensures long life and enables very high external radial and axial loads.

The standard hollow output shaft made of steel (shrink disc available on request), the option of mounting an output flange on one or both sides and the possibility of mounting a backstop device make these gear units extremely versatile and easy to install.

Gearbox housing, flanges, bells and covers are externally painted with BLUE RAL 5010, except for bevel helical gearboxes size 56 and size 63 which are made in aluminium.

2.1 Merkmale

Erhältlich in 9 Größen zu je 2 Untersetzungsstufen und in 8 Größen zu je 3 Untersetzungsstufen.

Vorgesehen sind drei Antriebsarten: mit vorstehender Antriebswelle, mit Auslegung für Motoranschluß (Glocke und Kupplung), mit Kompaktauslegung für Motoranschluß (Größe 56 und 63 Ausgenommen). Die drei Antriebstypen können alle sowohl bei der vertikalen als auch der horizontalen Ausführung verwendet werden.

Das Getriebegehäuse ist aus Aluminiumlegierung GAISi9Cu1 UNI7369/3 (56-63), Maschinenguß EN GJL 200 UNI EN 1561 (71-180) oder aus Sphäroguß EN GJS 400-15 U UNI EN 1563 (200-225) und mit Rippen versehen, die Starrheit gewährleisten; die Bearbeitung aller Flächen ermöglicht eine leichte Positionierung; eine einzige Schmierkammer gewährleistet eine höhere Wärmedissipation und eine bessere Schmierung aller inneren Elemente.

Die Zahnräder bestehen aus legiertem Einsatzstahl, sie wurden einsatz- und abschreckgehärtet. Insbesondere, die erste Untersetzungsstufe besteht aus zwei spiralverzahnten GLEASON-Kegelrädern mit sorgfältig geschliffenen Profil aus einsatz- und abschreckgehärtetem 16CrNi4- oder 18NiCrMo5-Stahl UNI7846.

An allen Achsen wurden Qualitäts-Kegelrollenlager verwendet (Ausnahme: Muffe am Antrieb bei Kompaktauslegung, diese wird von Schrägkugellagern gehalten); diese gewährleisten eine hohe Lebensdauer und das Aushalten von sehr hoher äußerer Radial- und Axialbelastungen.

Die serienmäßige Abtriebshohlwelle aus Stahl (auf Wunsch mit Schrumpfscheibe erhältlich), die Möglichkeit der Montage eines Abtriebsflansches an einer oder an beiden Seiten und die Auslegung für die Montage der Rücklaufsperrung heben die Vielseitigkeit dieser Untersetzungsgetriebe hervor und erleichtern ihren Einbau.

Getriebegehäuse, Flansche, Glocken und Deckel werden mit BLAU RAL 5010 lackiert (mit Ausnahme von Kegelstirnradgetriebe Größe 56 und 63, die aus Aluminium bestehen).

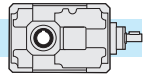

2.2 Designazione

2.2 Designation

2.2 Bezeichnung

Macchina Machine Maschine	Tipo entrata Input type Antriebsart	Grandezza Size Größe	Rotismo Gearing Räderwerk	Rapporto rid. Ratio Untersetzungsverhältnis	Predisposiz. Motor coupling Motoranschluss	Esecuzione Execution Ausführung	Posizione di montaggio Mounting position Baulege	Flangia uscita Output flange Abtriebsflansch	Antiritorno Back-stop device Rücklaufsperrle	Calettatore Shrink disk Schrumpfscheibe	Entrata supplementare Additional input Zusatzantrieb
T	A	112	B	10/1	P.A.M.	O	B3	FLS	CW	C.S.	S.e.A.
Riduttore ad assi ortogonali Bevel helical gearbox Kegelstirnradgetriebe	A	56 63 71 90 112 140 180 200 225	B	in = .../1 5 630	56 225	O	B3 B6 B7 B8 VA VB	FLS	AW	C.S.	A
	C	56 63 80 100 125 160 180 200	C					FLD	CW	C.D.	C
	F					V		2FL			F

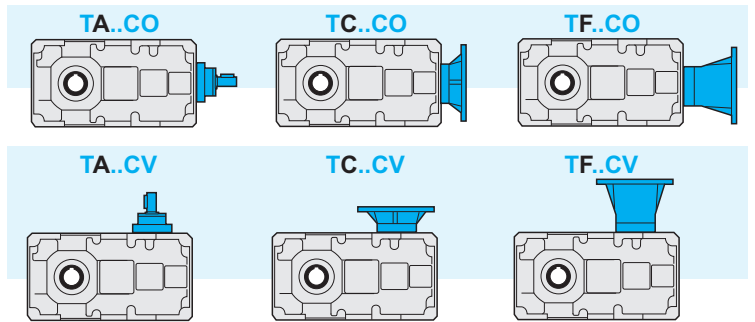
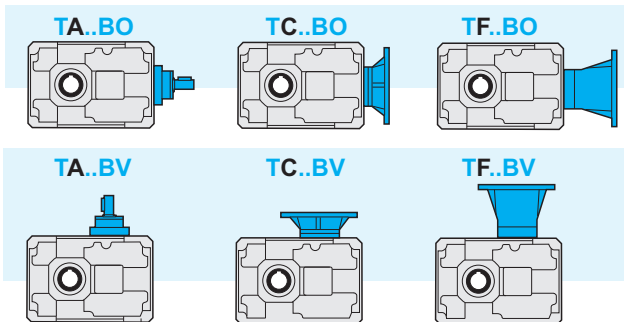

Documento scaricabile dal sito: www.emporiodelcuscinetto.it

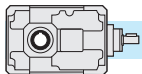

2.3 Sensi di rotazione alberi

Nei riduttori esecuzione orizzontale, per ottenere il senso di rotazione contrario al catalogo dell' albero lento mantenendo invariato il senso di rotazione dell' albero veloce, è sufficiente ruotare il riduttore di 180° attorno all' asse dell'albero veloce, utilizzando in pratica il piano di fissaggio opposto.

Nei riduttori esecuzione verticale è possibile fornire il senso di rotazione contrario al catalogo specificandolo al momento dell' ordine.

2.3 Direction of shaft rotation

With regard to horizontal mounted gearboxes, in order to get output rotation in a direction opposite to that given in the catalogue, nevertheless keeping input rotation unchanged, simply turn the gearbox 180° around the input shaft; in practice, mount the other way up.

Vertical units can be supplied with rotation direction opposite to that given in the catalogue; specify when ordering.

2.3 Drehrichtungen der Wellen

Wenn bei Untersetzungsgetrieben in waagerechter Ausführung für die Abtriebswelle eine andere als die im Katalog angegebene Drehrichtung gewünscht wird und die Antriebswelle ihre Drehrichtung beibehalten soll, so genügt es, das Getriebe um 180° um die Achse der Antriebswelle zu drehen, d.h. die gegenüberliegende Anschlußfläche zu verwenden.

Untersetzungsgetrieben in vertikaler Ausführung sind mit gegensätzlicher Drehrichtung lieferbar, deswegen ist es bei der Bestellung anzugeben, falls die umgekehrte Drehrichtung gewünscht wird.

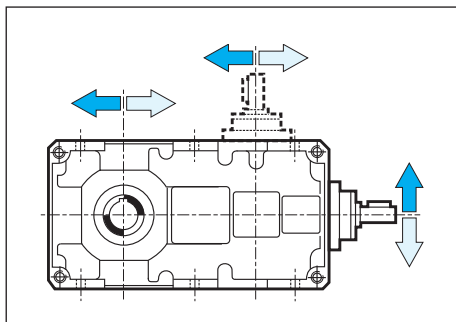

**Sensi di rotazione standard
Standard direction of rotation
Standarddrehrichtungen.**

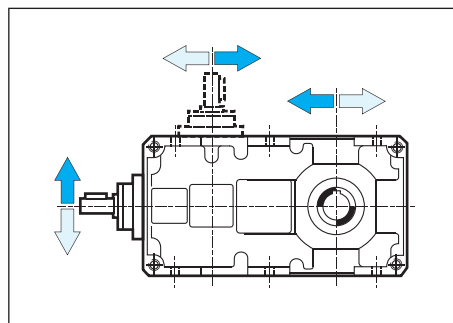

2.4 Entrata supplementare

La lavorazione del corpo prevede la possibilità di montare indifferentemente l'albero entrata nella posizione orizzontale (O) o verticale (V) per tutte le grandezze dei riduttori escludendo la grandezza 56 e la 63. Il cambio di versione può essere facilmente realizzato anche successivamente al primo montaggio.

Fatta esclusione per le grandezze 56 e 63, esiste la possibilità di montare la seconda entrata scegliendola, in base alle necessità, tra quelle previste: TA, TC, TF.

In questo caso occorre definire la versione del riduttore con l'entrata principale e specificare quindi la seconda entrata.

2.4 Additional input

The input shaft can be mounted either horizontally (O) or vertically (V) on all sizes except for 56 and 63. The version can be easily changed even after the first assembly.

Except for sizes 56 and 63, there is the possibility of mounting a second input; the available options are TA, TC, TF.

Both the main input and the additional second input shall be specified when ordering.

2.4 Zusatzantrieb

Die Antriebswelle kann entweder waagrecht (O) oder senkrecht (V) montiert werden (Größe 56 und 63 Ausgenommen). Auch nach der ersten Montage kann die Version leicht geändert werden. Mit Ausnahme von den Größen 56 und 63 kann eine zweite Antrieb TA, TC oder TF montiert werden.

Bei der Bestellung sollen sowohl die hauptsächliche Antrieb als auch die zweite Antrieb angegeben werden.

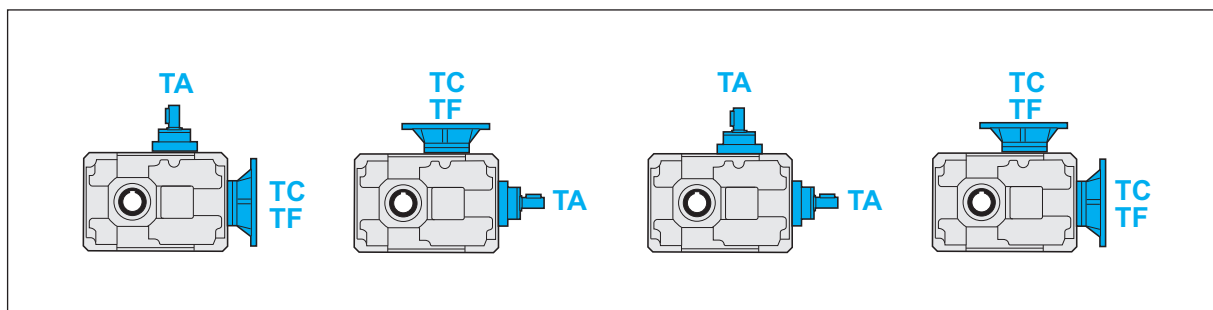

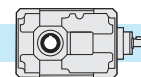

2.5 Velocità in entrata

Tutte le prestazioni dei riduttori sono calcolate in base ad una velocità in entrata di 1400 min^{-1} .

Tutti i riduttori ammettono velocità fino a 3000 min^{-1} anche se è consigliabile, dove l'applicazione lo permette, utilizzare valori inferiori a 1400 min^{-1} .

Nella tabella sottostante riportiamo i coefficienti correttivi della potenza in entrata P alle varie velocità riferita ad $F_s = 1$

Tab. 1

n_1 (rpm)	3000	2800	2200	1800	1400	900	700	500
Pc (kW)	P x 1.9	P x 1.8	P x 1.48	P x 1.24	P x 1	P x 0.7	P x 0.56	P x 0.42

2.6 Rendimento

Il valore del rendimento dei riduttori può essere stimato con sufficiente approssimazione in base al numero di riduzioni, trascurando le variazioni non significative attribuibili alle varie grandezze e rapporti.

2.5 Input speed

All calculations of gear unit performance are based on an input speed of 1400 min^{-1} .

All gear units permit speed up to 3000 min^{-1} , nevertheless it is advisable to keep below 1400 min^{-1} , depending on application.

The table below reports input power P corrective coefficients at the various speeds, with $F_s = 1$.

2.5 Antriebsdrehzahl

Bei der Berechnung der Getriebeleistungen wurde eine Antriebsdrehzahl von 1400 min^{-1} berücksichtigt.

Bei allen Getriebe sind Antriebsdrehzahlen bis 3000 min^{-1} möglich; es ist jedoch ratsam, die Drehzahlen unter 1400 min^{-1} zu halten, wenn die Anwendung es ermöglicht.

In der folgenden Tabelle finden Sie die Korrekturkoeffizienten für die Antriebsleistung P bei den verschiedenen Drehzahlen, bezogen auf $F_s = 1$.

2.6 Efficiency

The efficiency value of the gear units can be estimated sufficiently well on the basis of the number of reduction stages, ignoring non-significant variations which can be attributed to the various sizes and ratios.

2.6 Wirkungsgrad

Der Wirkungsgrad der Getriebe kann mit ausreichender Annäherung aufgrund der Anzahl der Untersetzungsstufen ermittelt werden, dabei können die unwesentlichen Veränderungen, die auf die verschiedenen Größen und Untersetzungsverhältnisse zurückzuführen sind, außer acht gelassen werden.

	T...B	T...C
	0.95	0.93

2.7 Potenza termica

I valori delle potenze termiche, P_{t0} (kW), relative alle diverse grandezze di riduttori ortogonali sono riportati nella tabella seguente in funzione della velocità di rotazione in entrata del riduttore

2.7 Thermal power

The following table shows the values of thermal power P_{t0} (kW) for each gearbox size on the basis of rotation speed at gearbox input.

2.7 Thermische Leistung

Die folgende Tabelle enthält die Werte P_{t0} der thermischen Leistung (kW) je nach Getriebegröße und abhängig von Drehzahlen am Getriebeantrieb.

Tab. 2

T	Potenza Termica / Thermal power / Thermische Leistung P_{t0} [kW]	
	n_1 [min^{-1}]	
	1400	2800
T56B	4.0	3.4
T63B	5.5	4.7
TA71B	4.4	3.8
TA90B	6.7	5.7
TA112B	10.1	8.6
TA140B	15.2	12.9
TA180B	24.6	20.9
TA200B	31.5	26.8
TA225B	39.9	33.9
T56C	3.3	2.8
T63C	4.2	3.6
TA80C	5.0	4.3
TA100C	7.6	6.5
TA125C	11.5	9.8
TA160C	18.3	15.6
TA180C	22.9	19.4
TA200C	29.9	25.4

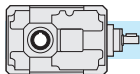

2.8 Dati tecnici

2.8 Technical data

2.8 Technische Daten

T	n ₁ = 1400			TC - TF				TA	
	in	ir	n ₂ rpm	T ₂ Nm	P1 kW	FS'	IEC	T _{2M} Nm	P kW
56B	8	8.06	174	94	1.8	1.2		110	2.1
	10	10.17	138	119	1.8	1.0	56	120	1.8
	12.5	12.31	114	120	1.5	1.1	63 (B5)	130	1.6
	16	15.00	93	107	1.1	1.3	71	140	1.4
	20	20.33	69	119	0.9	1.2	80	140	1.1
	25	24.62	57	120	0.75	1.2	90 (B5)	140	0.90
	31.5	30.00	47	107	0.55	1.3	(B14)	140	0.70
	40	39.38	36	140	0.55	1.0	TF	140	0.55
	50	48.00	29	115	0.37	1.2		140	0.45
56C	40	40.28	35	95	0.37	1.4		135	0.53
	50	50.83	28	119	0.37	1.2	56	140	0.43
	63	61.54	23	98	0.25	1.4	63 (B5)	140	0.36
	80	75.00	19	119	0.25	1.2	71	145	0.30
	100	101.67	14	116	0.18	1.2	80	145	0.22
	125	123.08	11	141	0.18	1.0	90 (B5)	145	0.19
	160	150.00	9	124	0.13	1.2	(B14)	145	0.15
	200	196.92	7	112	0.09	1.3	TF	145	0.10
	250	240.00	6	137	0.09	1.1		150	0.10
63B	8	7.94	176	93	1.8	1.7		155	3.0
	10	10.18	138	119	1.8	1.4	56	170	2.6
	12.5	12.50	112	146	1.8	1.3	63 (B5)	185	2.3
	16	15.88	88	185	1.8	1.1	71	200	1.9
	20	20.36	69	198	1.5	1.0	80	200	1.5
	25	25.00	56	178	1.1	1.1	90 (B5)	200	1.2
	31.5	31.00	45	181	0.9	1.1	(B14)	200	1.0
	40	40.00	35	194	0.75	1.0	TF	200	0.80
	50	49.60	28	177	0.55	1.1		200	0.60
63C	40	39.71	35	189	0.75	1.1		200	0.79
	50	50.89	28	178	0.55	1.2	56	210	0.65
	63	62.50	22	147	0.37	1.4	63 (B5)	210	0.53
	80	79.41	18	186	0.37	1.1	71	210	0.42
	100	101.79	14	161	0.25	1.3	80	210	0.33
	125	125.00	11	198	0.25	1.1	90 (B5)	210	0.26
	160	155.00	9	177	0.18	1.2	(B14)	210	0.21
	200	200.00	7	165	0.13	1.3	TF	210	0.17
	250	248.00	6	205	0.13	1.0		210	0.13
71B	10	10.25	137	120	1.8	1.9		230	3.5
	12.5	13.05	107	152	1.8	1.6	63	240	2.8
	16	15.63	90	182	1.8	1.4	71	250	2.5
	20	19.64	71	229	1.8	1.3	80	290	2.3
	25	24.99	56	243	1.5	1.2	90 (B5)	280	1.7
	31.5	29.95	47	213	1.1	1.2	TC-TF	260	1.3
	40	38.73	36	226	0.9	1.1	80	240	1.0
	50	50.18	28	244	0.75	1.1	(B14)	260	0.80
	63	60.13	23	214	0.55	1.2	TC	260	0.70
80	77.76	18	186	0.37	1.3		240	0.50	

T	n ₁ = 1400			TC - TF				TA	
	in	ir	n ₂ rpm	T ₂ Nm	P1 kW	FS'	IEC	T _{2M} Nm	P kW
90B	5*	4.56	307	118	4	3.2		380	12.8
	6.3*	6.26	224	162	4	2.5		405	10.0
	10	10.25	137	266	4	1.8	71	480	7.2
	12.5	13.05	107	338	4	1.6	80	530	6.3
	16	15.63	90	405	4	1.4	90 100 112 (B5)	550	5.4
	20	19.64	71	509	4	1.2	(B5)	620	4.9
	25	24.99	56	486	3	1.3	TC-TF	630	3.9
	31.5	29.95	47	427	2.2	1.3	90	560	2.9
	40	38.73	36	452	1.8	1.1	(B14)	500	2.0
80C	50	50.18	28	488	1.5	1.1	TC	550	1.7
	63	60.13	23	429	1.1	1.3		570	1.5
	80	77.76	18	454	0.9	1.1		505	1.0
	50	52.18	27	596	1.8	1.1		660	2.0
	63	62.53	22	595	1.5	1.1		680	1.7
	80	79.58	18	555	1.1	1.3	63	710	1.4
	100	99.97	14	698	1.1	1.1	71	740	1.2
	125	119.78	12	684	0.9	1.1	80	740	1.0
	160	152.45	9	532	0.55	1.3	90 (B5)	680	0.70
112B	200	182.67	8	637	0.55	1.1	TC-TF	700	0.60
	250	240.51	6	565	0.37	1.3	80	750	0.49
	315	306.11	5	719	0.37	1.0	(B14)	740	0.38
	400	366.78	4	582	0.25	1.2	TC	700	0.30
	500	474.35	3	542	0.18	1.2		660	0.22
	630	613.46	2	506	0.13	1.2		620	0.16
	5*	4.86	288	290	9.2	1.5		440	14.0
	10	10.25	137	611	9.2	1.5		920	13.9
	12.5	13.05	107	778	9.2	1.3		1000	11.8
16	15.63	90	932	9.2	1.2	80	1100	10.9	
20	19.64	71	1171	9.2	1.0	90	1190	9.4	
25	24.99	56	1215	7.5	1.1	100	1190	9.4	
31.5	29.95	47	1067	5.5	1.1	112	1280	7.9	
40	38.73	36	1004	4	1.0	132 (B5)	1220	6.3	
50	50.18	28	976	3	1.1	TC-TF	1050	4.2	
63	60.13	23	857	2.2	1.4		1070	3.3	
80	77.76	18	907	1.8	1.2		1240	3.2	
100C	50	52.18	27	993	3	1.3		1300	3.9
	63	62.53	22	1190	3	1.1	71	1350	3.4
	80	79.58	18	1111	2.2	1.3	80	1410	2.8
	100	99.97	14	1395	2.2	1.1	90	1470	2.3
	125	119.78	12	1368	1.8	1.1	100	1470	2.3
	160	152.45	9	1064	1.1	1.3	112	1480	1.9
	200	182.67	8	1275	1.1	1.1	(B5)	1360	1.4
	250	240.51	6	1144	0.75	1.3	TC-TF	1400	1.2
	315	306.11	5	1456	0.75	1.0	90	1480	0.80
400	366.78	4	1280	0.55	1.1	(B14)	1400	0.60	
500	474.35	3	1113	0.37	1.2	TC	1360	0.50	
630	613.46	2	973	0.25	1.3		1240	0.30	

Flange quadrate / Square flanges / Viereckige Flansche

* Rapporti speciali / Special ratios / Sonderverhältnisse

Documento scaricabile dal sito: www.emporiodelcuscinetto.it

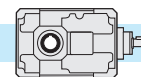

2.8 Dati tecnici

2.8 Technical data

2.8 Technische Daten

T	n ₁ = 1400			TC - TF				TA	
	in	ir	n ₂ rpm	T ₂ Nm	P ₁ kW	FS'	IEC	T _{2M} Nm	P kW
140B	7*	6.88	203	983	22	1.4	TC-TF	1350	30.2
	10	10.25	137	1461	22	1.3		1850	27.9
	12.5	13.05	107	1860	22	1.1		2050	24.3
	16	15.63	90	1874	18.5	1.2		2200	21.7
	20	19.64	71	2354	18.5	1.0		2400	18.9
	25	24.99	56	2429	15	1.0		2540	15.7
	31.5	29.95	47	2135	11	1.1		2300	11.9
	40	38.73	36	1882	7.5	1.2		2210	8.8
	50	50.18	28	1789	5.5	1.2		2120	6.5
	63	60.13	23	2143	5.5	1.1		2350	6.0
80	77.76	18	2016	4	1.1	2250	4.5		
125C	50	52.18	27	2483	7.5	1.1	TC-TF	2650	8.0
	63	62.53	22	2182	5.5	1.3		2760	7.0
	80	79.58	18	2777	5.5	1.0		2880	5.7
	100	99.97	14	2537	4	1.2		3000	4.7
	125	119.78	12	2280	3	1.3		3000	4.0
	160	152.45	9	2128	2.2	1.3		2720	2.8
	200	182.67	8	2549	2.2	1.1		2800	2.4
	250	240.51	6	2746	1.8	1.1		3050	2.0
	315	306.11	5	2913	1.5	1.0		2960	1.5
	400	366.78	4	2560	1.1	1.1		2800	1.2
180B	10	10.25	137	1993	30	2.0	TC-TF	3900	58.7
	12.5	13.05	107	2536	30	1.7		4300	50.9
	16	15.63	90	3039	30	1.5		4500	44.4
	20	19.64	71	3818	30	1.3		5100	40.1
	25	24.99	56	4859	30	1.1		5230	32.3
	31.5	29.95	47	4269	22	1.1		4680	24.1
	40	38.73	36	3764	15	1.1		4300	17.1
	50	50.18	28	3577	11	1.2		4300	13.2
	63	60.13	23	4286	11	1.1		4780	12.3
	80	77.76	18	3779	7.5	1.2		4380	8.7
160C	50	52.18	27	4966	15	1.0	TC-TF	5130	15.5
	63	62.53	22	4363	11	1.2		5350	13.5
	80	79.58	18	4644	9.2	1.2		5570	11.0
	100	99.97	14	4756	7.5	1.2		5800	9.2
	125	119.78	12	5699	7.5	1.0		5800	7.6
	160	152.45	9	5319	5.5	1.0		5470	5.7
	200	182.67	8	4635	4	1.2		5600	4.8
	250	240.51	6	4577	3	1.3		5890	3.3
	315	306.11	5	5826	3	1.0		5920	3.0
	400	366.78	4	5119	2.2	1.1		5600	2.4
500	474.35	3	4514	1.5	1.2	5280	1.8		
630	613.46	2	4281	1.1	1.2	4960	1.3		

T	n ₁ = 1400			TC - TF				TA	
	in	ir	n ₂ rpm	T ₂ Nm	P ₁ kW	FS'	IEC	T _{2M} Nm	P kW
200B	8	8.14	172	1582	30	3.2	TC-TF	5000	94.8
	10	10.43	134	2028	30	2.7		5500	81.4
	12.5	12.60	111	2449	30	2.4		6000	73.5
	16	15.63	90	3039	30	2.1		6500	64.2
	20	17.65	79	3432	30	2.1		7100	62.1
	25	24.14	58	4692	30	1.5		7150	45.7
	31.5	29.95	47	5822	30	1.2		7250	37.4
	40	33.82	41	6575	30	1.1		7300	33.3
	50	47.93	29	6833	22	1.1		7400	23.8
	63	54.13	26	6489	18.5	1.1		7400	21.1
180C	50	53.11	26	6234	18.5	1.2	TC-TF	7240	21.5
	63	63.64	22	6056	15	1.2		7280	18.0
	80	76.85	18	7313	15	1.0		7420	15.2
	100	99.39	14	6936	11	1.1		7500	11.9
	125	122.88	11	7172	9.2	1.0		7500	9.6
	160	147.23	10	7005	7.5	1.1		7550	8.1
	200	190.41	7	6644	5.5	1.1		7600	6.3
	250	246.73	6	6261	4	1.2		7650	4.9
	315	295.63	5	7502	4	1.0		7700	4.1
	400	382.33	4	7276	3	1.1		7950	3.3
225B	8	8.44	166	2461	45	3.0	TF	7500	137.1
	10	10.13	138	2955	45	2.8		8300	126.4
	12.5	12.45	112	3630	45	2.5		9100	112.8
	16	15.93	88	4644	45	2.2		10000	96.9
	20	19.13	73	5577	45	1.9		10700	86.3
	25	23.49	60	6850	45	1.6		11000	72.3
200C	31.5	30.29	46	8832	45	1.3	TC-TF	11100	56.6
	40	37.09	38	8892	37	1.2		10800	44.9
	40	42.62	33	8110	30	1.3		10900	40.3
	50	51.18	27	9740	30	1.1		11000	33.9
	63	62.86	22	8772	22	1.3		11350	28.5
	80	76.97	18	10742	22	1.0		11050	22.6
	100	98.04	14	9330	15	1.2		11200	18.0
	125	120.41	12	11459	15	1.0		11500	15.1
	160	147.45	9	10290	11	1.1		11200	12.0
	200	196.87	7	9367	7.5	1.2		11400	9.1
250	241.79	6	11504	7.5	1.0	11700	7.6		
315	296.07	5	10330	5.5	1.1	11850	6.3		

Flange quadrate / Square flanges / Viereckige Flansche

* Rapporto speciale / Special ratio / Sonderverhältnisse

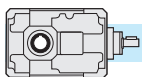





2.9 **Momenti d'inerzia** [Kg·cm²]
(riferiti all'albero veloce in entrata)



2.9 **Moments of inertia** [Kg·cm²]
(referred to input shaft)

2.9 **Trägheitsmoment** [Kg·cm²]
(bez. Antriebswelle)

TA..B - TC..B - TF..B

56B	i _n	TA 	TF 				
			IEC B5				
			56	63	71	80	90
8	0.25	0.32	0.32	0.40	0.60	0.77	
10	0.22	0.29	0.29	0.37	0.56	0.74	
12.5	0.20	0.27	0.27	0.35	0.54	0.72	
16	0.18	0.25	0.26	0.33	0.53	0.71	
20	0.08	0.15	0.15	0.22	0.42	0.60	
25	0.07	0.14	0.15	0.22	0.42	0.59	
31.5	0.07	0.14	0.14	0.21	0.41	0.59	
40	0.04	0.11	0.12	0.19	0.39	0.56	
50	0.04	0.11	0.11	0.19	0.39	0.56	

63B	i _n	TA 	TF 				
			IEC B5				
			56	63	71	80	90
8	0.40	0.47	0.47	0.55	0.74	0.92	
10	0.34	0.41	0.42	0.49	0.69	0.87	
12.5	0.31	0.38	0.38	0.45	0.65	0.83	
16	0.16	0.23	0.24	0.31	0.51	0.68	
20	0.15	0.22	0.22	0.29	0.49	0.67	
25	0.14	0.21	0.21	0.29	0.48	0.66	
31.5	0.13	0.20	0.21	0.28	0.48	0.65	
40	0.07	0.15	0.15	0.22	0.42	0.60	
50	0.07	0.14	0.15	0.22	0.42	0.60	
63	0.07	0.14	0.15	0.22	0.42	0.59	

71B	i _n	TA 	TC 				TF 			
			IEC B5				IEC B5			
			63	71	80	90	63	71	80	90
10	0.95	1.00	1.14	1.52	1.57	1.20	1.22	1.89	2.96	
12.5	0.89	0.94	1.08	1.46	1.51	1.14	1.16	1.83	2.90	
16	0.85	0.91	1.05	1.43	1.47	1.11	1.12	1.80	2.87	
20	0.38	0.43	0.57	0.94	0.99	0.63	0.65	1.32	2.39	
25	0.36	0.41	0.55	0.93	0.98	0.61	0.63	1.31	2.37	
31.5	0.35	0.40	0.54	0.92	0.97	0.61	0.62	1.30	2.36	
40	0.34	0.39	0.53	0.91	0.96	0.60	0.61	1.29	2.35	
50	0.19	0.22	0.36	0.74	0.79	0.44	0.46	1.14	2.20	
63	0.19	0.22	0.36	0.74	0.79	0.44	0.46	1.14	2.20	
80	0.19	0.22	0.36	0.74	0.79	0.44	0.46	1.13	2.20	

Documento scaricabile dal sito: www.emporiodelcuscinetto.it

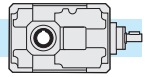

2.9 **Momenti d'inerzia** [Kg·cm²]
(riferiti all'albero veloce in entrata)

2.9 **Moments of inertia** [Kg·cm²]
(referred to input shaft)

2.9 **Trägheitsmoment** [Kg·cm²]
(bez. Antriebswelle)

TA..B - TC..B - TF..B

90B	i _n	TA	TC				TF			
			IEC B5				IEC B5			
			71	80	90	110-112	71	80	90	110-112
5*	4.36	4.77	4.94	5.31	6.15	5.22	5.35	6.53	8.70	
6.3*	3.67	4.07	4.24	4.62	5.46	4.52	4.66	5.84	8.00	
10	2.77	3.18	3.35	3.73	4.57	3.63	3.77	4.94	7.11	
12.5	2.60	3.01	3.18	3.56	4.40	3.46	3.60	4.77	6.94	
16	2.49	2.90	3.07	3.44	4.28	3.35	3.48	4.66	6.82	
20	1.16	1.53	1.70	2.08	2.92	2.02	2.16	3.33	5.50	
25	1.12	1.49	1.66	2.04	2.88	1.98	2.11	3.29	5.45	
31.5	1.09	1.46	1.63	2.00	2.84	1.94	2.08	3.25	5.42	
40	1.06	1.43	1.60	1.98	2.82	1.92	2.05	3.23	5.40	
50	0.65	0.98	1.15	1.53	2.37	1.50	1.64	2.81	4.98	
63	0.64	0.97	1.14	1.52	2.36	1.50	1.63	2.81	4.97	
80	0.63	0.97	1.14	1.51	2.35	1.49	1.62	2.80	4.97	

112B	i _n	TA	TC				TF			
			IEC B5				IEC B5			
			80	90	110-112	132	80	90	110-112	132
5*	12.20	13.70	13.57	14.53	17.67	14.53	14.46	16.78	30.77	
10	8.51	9.44	9.31	10.26	13.40	10.84	10.77	13.09	27.08	
12.5	7.67	8.60	8.47	9.42	12.56	10.00	9.93	12.25	26.24	
16	7.27	8.20	8.07	9.03	12.16	9.61	9.54	11.85	25.85	
20	3.62	4.46	4.33	5.29	8.43	5.96	5.89	8.20	22.20	
25	3.39	4.23	4.10	5.06	8.20	5.73	5.66	7.97	21.97	
31.5	3.29	4.13	4.00	4.95	8.09	5.62	5.55	7.87	21.86	
40	3.21	4.05	3.92	4.87	8.01	5.55	5.47	7.79	21.79	
50	1.79	2.50	2.37	3.32	6.46	4.13	4.05	6.37	20.37	
63	1.77	2.47	2.35	3.30	6.44	4.10	4.03	6.34	20.34	
80	1.75	2.46	2.33	3.28	6.42	4.08	4.01	6.33	20.32	

140B	i _n	TA	TC						TF					
			IEC B5						IEC B5					
			80	90	110-112	132	160	180	80	90	110-112	132	160	180
7*	29.65	30.78	30.65	30.79	33.99	38.41	41.43	31.85	34.23	34.40	49.26	51.44	96.71	
10	25.04	26.17	26.04	26.18	29.38	33.80	36.82	27.23	29.62	29.79	44.65	46.83	92.10	
12.5	22.28	23.41	23.28	23.42	26.62	31.05	34.06	24.48	26.86	27.04	41.90	44.08	89.34	
16	21.26	22.39	22.26	22.40	25.60	30.02	33.04	23.46	25.84	26.01	40.87	43.05	88.32	
20	9.17	10.13	10.00	10.14	13.34	17.76	20.78	11.37	13.75	13.92	28.78	30.97	76.23	
25	8.42	9.38	9.25	9.39	12.59	17.01	20.03	10.62	13.00	13.17	28.03	30.22	75.48	
31.5	8.14	9.10	8.97	9.11	12.31	16.73	19.75	10.34	12.72	12.90	27.76	29.94	75.20	
40	7.92	8.87	8.74	8.88	12.08	16.51	19.52	10.11	12.49	12.67	27.53	29.71	74.98	
50	4.28	4.94	4.81	4.95	8.15	12.57	15.59	6.47	8.85	9.03	23.89	26.07	71.34	
63	4.21	4.87	4.74	4.88	8.08	12.50	15.52	6.40	8.79	8.96	23.82	26.00	71.27	
80	4.15	4.81	4.68	4.82	8.02	12.44	15.46	6.35	8.73	8.91	23.77	25.95	71.21	

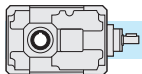







2.9 **Momenti d'inerzia** [Kg·cm²]
(riferiti all'albero veloce in entrata)



2.9 **Moments of inertia** [Kg·cm²]
(referred to input shaft)

2.9 **Trägheitsmoment** [Kg·cm²]
(bez. Antriebswelle)

TA..B - TC..B - TF..B

180B	i _n	TA 	 TC					 TF				
			IEC B5					IEC B5				
			100-112	132	160	180	200	100-112	132	160	180	200
10	78.24	80.83	86.51	85.51	88.42	98.81	97.86	99.23	101.41	150.52	147.05	
12.5	68.84	71.43	77.11	76.11	79.02	89.41	88.46	89.82	92.01	141.12	137.65	
16	66.22	68.81	74.49	73.49	76.40	86.79	85.84	87.20	89.38	138.50	135.03	
20	28.52	31.29	36.97	35.97	38.88	49.27	48.14	49.50	51.68	100.80	97.33	
25	25.96	26.14	31.82	30.82	33.73	44.12	45.58	46.94	49.12	98.24	94.77	
31.5	25.25	28.01	33.69	32.69	35.60	45.99	44.86	46.23	48.41	97.53	94.05	
40	24.43	27.19	32.88	31.88	34.79	45.17	44.04	45.41	47.59	96.71	93.23	
50	11.97	14.25	19.93	18.93	21.84	32.23	31.59	32.95	35.13	84.25	80.78	
63	11.80	14.07	19.75	18.75	21.66	32.05	31.41	32.78	34.96	84.08	80.60	
80	11.59	13.87	19.55	18.55	21.46	31.85	31.21	32.57	34.75	83.87	80.40	

200B	i _n	TA 	 TC					 TF				
			IEC B5					IEC B5				
			110-112	132	160	180	200	110-112	132	160	180	200
8	109.38	110.72	116.40	115.40	118.31	128.70	129.00	130.37	132.55	181.66	178.19	
10	95.71	97.05	102.73	101.73	104.64	115.03	115.33	116.69	118.87	167.99	164.52	
12.5	85.34	86.68	92.36	91.36	94.27	104.66	104.96	106.32	108.51	157.62	154.15	
16	79.58	80.92	86.60	85.60	88.51	98.90	99.20	100.56	102.74	151.86	148.39	
20	75.15	76.49	82.17	81.17	84.08	94.47	94.77	96.13	98.32	147.43	143.96	
25	31.37	32.88	38.56	37.56	40.47	50.86	50.98	52.35	54.53	103.65	100.17	
31.5	29.80	31.31	36.99	35.99	38.90	49.29	49.41	50.78	52.96	102.08	98.60	
40	28.59	30.11	35.79	34.79	37.70	48.09	48.21	49.57	51.75	100.87	97.40	
50	20.48	21.49	27.17	26.17	29.08	39.47	40.09	41.46	43.64	92.76	89.28	
63	20.01	21.02	26.70	25.70	28.61	39.00	39.62	40.99	43.17	92.29	88.81	

225B	i _n	TA 	 TF				
			IEC B5				
			132	160	150	200	225
8	265.00	337.3	345.3	343.3	339.8	342.6	
10	249.31	321.6	329.6	327.6	324.1	326.9	
12.5	234.27	306.6	314.5	312.5	309.1	311.9	
16	90.92	163.2	171.2	169.2	165.7	168.5	
20	86.52	158.8	166.8	164.8	161.3	164.1	
25	82.29	154.6	162.6	160.6	157.1	159.9	
31.5	68.32	140.6	148.6	146.6	143.1	145.9	
40	64.25	136.5	144.5	142.5	139.0	141.9	

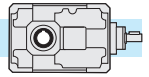





2.9 **Momenti d'inerzia** [Kg·cm²]
(riferiti all'albero veloce in entrata)



2.9 **Moments of inertia** [Kg·cm²]
(referred to input shaft)

2.9 **Trägheitsmoment** [Kg·cm²]
(bez. Antriebswelle)

TA..C - TC..C - TF..C

56C	i _n	TA 	TF 				
			IEC B5				
			56	63	71	80	90
40	0.06	0.136	0.139	0.212	0.410	0.588	
50	0.06	0.134	0.138	0.211	0.409	0.587	
63	0.06	0.134	0.137	0.210	0.408	0.586	
80	0.06	0.133	0.137	0.210	0.408	0.585	
100	0.06	0.129	0.132	0.205	0.403	0.581	
125	0.06	0.129	0.132	0.205	0.403	0.581	
160	0.06	0.128	0.132	0.205	0.403	0.581	
200	0.06	0.127	0.131	0.204	0.402	0.580	
250	0.06	0.127	0.131	0.204	0.402	0.580	

63C	i _n	TA 	TF 				
			IEC B5				
			56	63	71	80	90
40	0.07	0.142	0.145	0.218	0.416	0.594	
50	0.07	0.139	0.143	0.216	0.414	0.592	
63	0.07	0.138	0.142	0.215	0.413	0.590	
80	0.06	0.132	0.136	0.209	0.407	0.585	
100	0.06	0.132	0.135	0.208	0.406	0.584	
125	0.06	0.131	0.135	0.208	0.406	0.584	
160	0.06	0.131	0.135	0.208	0.406	0.583	
200	0.06	0.129	0.132	0.205	0.403	0.581	
250	0.06	0.129	0.132	0.205	0.403	0.581	
315	0.06	0.129	0.132	0.205	0.403	0.581	

80C	i _n	TA 	TC 				TF 			
			IEC B5				IEC B5			
			63	71	80	90	63	71	80	90
50	0.90	0.95	1.09	1.47	1.52	1.15	1.17	1.84	2.91	
63	0.86	0.91	1.05	1.43	1.48	1.11	1.13	1.81	2.87	
80	0.86	0.91	1.05	1.43	1.48	1.11	1.13	1.80	2.87	
100	0.36	0.41	0.55	0.93	0.98	0.62	0.63	1.31	2.38	
125	0.35	0.38	0.52	0.90	0.95	0.61	0.62	1.30	2.37	
160	0.35	0.40	0.54	0.92	0.97	0.61	0.62	1.30	2.36	
200	0.35	0.40	0.54	0.92	0.97	0.61	0.62	1.30	2.36	
250	0.19	0.22	0.36	0.74	0.79	0.44	0.46	1.14	2.20	
315	0.19	0.22	0.36	0.74	0.79	0.44	0.46	1.14	2.20	
400	0.19	0.22	0.36	0.74	0.79	0.44	0.46	1.14	2.20	
500	0.19	0.22	0.36	0.74	0.79	0.44	0.46	1.13	2.20	
630	0.19	0.22	0.36	0.74	0.79	0.44	0.46	1.13	2.20	

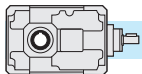







2.9 **Momenti d'inerzia** [Kg·cm²]
(riferiti all'albero veloce in entrata)



2.9 **Moments of inertia** [Kg·cm²]
(referred to input shaft)

2.9 **Trägheitsmoment** [Kg·cm²]
(bez. Antriebswelle)

TA..C - TC..C - TF..C

	i _n	TA 	 TC				 TF			
			IEC B5				IEC B5			
			71	80	90	110-112	71	80	90	110-112
100C	50	2.68	3.08	3.25	3.63	4.47	3.53	3.67	4.84	7.01
	63	2.56	2.96	3.13	3.51	4.35	3.41	3.55	4.72	6.89
	80	2.53	2.94	3.11	3.49	4.33	3.39	3.52	4.70	6.87
	100	1.14	1.51	1.68	2.06	2.89	2.00	2.13	3.31	5.47
	125	1.10	1.47	1.64	2.02	2.86	1.96	2.10	3.27	5.44
	160	1.10	1.47	1.64	2.02	2.86	1.96	2.09	3.27	5.44
	200	1.10	1.47	1.64	2.01	2.85	1.95	2.09	3.26	5.43
	250	0.64	0.98	1.15	1.52	2.36	1.50	1.63	2.81	4.98
	315	0.64	0.97	1.14	1.52	2.36	1.50	1.63	2.81	4.98
	400	0.64	0.97	1.14	1.52	2.36	1.50	1.63	2.81	4.98
	500	0.63	0.97	1.14	1.51	2.35	1.49	1.62	2.80	4.97
	630	0.63	0.97	1.14	1.51	2.35	1.49	1.62	2.80	4.97

	i _n	TA 	 TC				 TF			
			IEC B5				IEC B5			
			80	90	110-112	132	80	90	110-112	132
125C	50	7.82	8.75	8.62	9.57	12.71	10.16	10.08	12.40	26.40
	63	7.46	8.39	8.26	9.22	12.36	9.80	9.73	12.04	26.04
	80	7.39	8.32	8.19	9.14	12.28	9.72	9.65	11.97	25.96
	100	3.44	4.28	4.15	5.10	8.24	5.77	5.70	8.02	22.01
	125	3.34	4.18	4.05	5.00	8.14	5.67	5.60	7.92	21.91
	160	3.32	4.16	4.03	4.98	8.12	5.65	5.58	7.90	21.89
	200	3.31	4.15	4.02	4.97	8.11	5.65	5.57	7.89	21.89
	250	1.78	2.49	2.36	3.31	6.45	4.11	4.04	6.36	20.35
	315	1.77	2.48	2.35	3.31	6.45	4.11	4.04	6.35	20.35
	400	1.77	2.48	2.35	3.30	6.44	4.11	4.03	6.35	20.35
	500	1.75	2.46	2.33	3.28	6.42	4.08	4.01	6.33	20.32
	630	1.75	2.46	2.33	3.28	6.42	4.08	4.01	6.33	20.32

	i _n	TA 	 TC						 TF					
			IEC B5						B5					
			80	90	110-112	132	160	180	80	90	110-112	132	160	180
160C	50	23.13	24.26	24.13	24.27	27.47	31.89	34.91	25.33	27.71	27.88	42.74	44.92	90.19
	63	22.01	23.14	23.01	23.15	26.35	30.77	33.79	24.21	26.59	26.77	41.63	43.81	89.07
	80	21.76	22.89	22.76	22.90	26.10	30.52	33.54	23.96	26.34	26.51	41.37	43.56	88.82
	100	8.65	9.61	9.48	9.62	12.82	17.24	20.26	10.85	13.23	13.40	28.26	30.45	75.71
	125	8.35	9.30	9.17	9.31	12.51	16.94	19.95	10.54	12.92	13.10	27.96	30.14	75.41
	160	8.28	9.23	9.10	9.24	12.44	16.87	19.88	10.47	12.86	13.03	27.89	30.07	75.34
	200	8.26	9.21	9.09	9.22	12.42	16.85	19.87	10.46	12.84	13.01	27.87	30.05	75.32
	250	4.26	4.92	4.79	4.93	8.13	12.55	15.57	6.46	8.84	9.01	23.87	26.05	71.32
	315	4.24	4.90	4.77	4.91	8.11	12.53	15.55	6.44	8.82	9.00	23.86	26.04	71.30
	400	4.24	4.90	4.77	4.91	8.11	12.53	15.55	6.43	8.81	8.99	23.85	26.03	71.30
	500	4.17	4.83	4.70	4.84	8.03	12.46	15.48	6.36	8.74	8.92	23.78	25.96	71.23
	630	4.16	4.82	4.69	4.83	8.03	12.45	15.47	6.36	8.74	8.92	23.78	25.96	71.22

Documento scaricabile dal sito: www.emporiodelcuscinetto.it

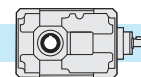







2.9 **Momenti d'inerzia** [Kg·cm²]
(riferiti all'albero veloce in entrata)

2.9 **Moments of inertia** [Kg·cm²]
(referred to input shaft)

2.9 **Trägheitsmoment** [Kg·cm²]
(bez. Antriebswelle)

TA..C - TC..C - TF..C

180C	i _n	TA 	TC 						TF 					
			IEC B5						IEC B5					
			80	90	110-112	132	160	180	80	90	110-112	132	160	180
			50	23.76	24.89	24.76	24.90	28.10	32.52	35.54	25.95	28.34	28.51	43.37
63	22.45	23.58	23.45	23.59	26.79	31.21	34.23	24.65	27.03	27.20	42.06	44.25	89.51	
80	22.17	23.30	23.17	23.31	26.51	30.93	33.95	24.37	26.75	26.93	41.79	43.97	89.23	
100	20.94	22.07	21.94	22.07	25.27	29.70	32.72	23.13	25.51	25.69	40.55	42.73	88.00	
125	8.71	9.67	9.54	9.68	12.88	17.30	20.32	10.91	13.29	13.47	28.33	30.51	75.77	
160	8.39	9.35	9.22	9.36	12.56	16.98	20.00	10.59	12.97	13.14	28.00	30.18	75.45	
200	8.05	9.01	8.88	9.02	12.22	16.64	19.66	10.25	12.63	12.81	27.67	29.85	75.11	
250	4.35	5.01	4.88	5.02	8.22	12.64	15.66	6.55	8.93	9.10	23.96	26.14	71.41	
315	4.27	4.93	4.80	4.94	8.14	12.56	15.58	6.47	8.85	9.02	23.88	26.06	71.33	
400	4.18	4.84	4.72	4.85	8.05	12.48	15.50	6.38	8.76	8.94	23.80	25.98	71.25	

200C	i _n	TA 	TC 					TF 				
			IEC B5					IEC B5				
			110-112	132	160	180	200	110-112	132	160	180	200
			40	72.31	74.90	80.58	79.58	82.49	92.88	91.93	93.29	95.47
50	71.70	74.28	79.97	78.97	81.87	92.26	91.31	92.68	94.86	143.98	140.50	
63	71.11	73.69	79.38	78.38	81.28	91.67	90.72	92.09	94.27	143.39	139.91	
80	70.63	73.22	78.90	77.90	80.81	91.20	90.24	91.61	93.79	142.91	139.43	
100	26.74	29.50	35.19	34.19	37.09	47.48	46.35	47.72	49.90	99.02	95.54	
125	26.58	29.34	35.03	34.02	36.93	47.32	46.19	47.56	49.74	98.86	95.38	
160	26.45	29.21	34.90	33.89	36.80	47.19	46.06	47.43	49.61	98.73	95.25	
200	12.17	14.44	20.12	19.12	22.03	32.42	31.78	33.15	35.33	84.45	80.97	
250	12.13	14.40	20.09	19.08	21.99	32.38	31.74	33.11	35.29	84.41	80.93	
315	12.09	14.37	20.05	19.05	21.96	32.35	31.71	33.07	35.25	84.37	80.90	

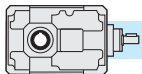

2.10 Dimensioni

2.10 Dimensions

2.10 Abmessungen

	TA...- TF...				
	56B		63B		
R	73.5		75		
F	9		9		
e	45		50		
H h8	65		70		
X h8	65		80		
E h8	65		70		
M	M8		M8		
C f8	70		80		
K	85		100		
L	59		65		
S	71		85		
f	9		9		
m	45		55		
c	73.5		80		
N2	6	8	8	8	8
M2	22.8	28.3	28.3	31.3	33.3
D2 H7	20	25	25	28	30
b	73.5		75		
r	45		50		
B	92		111		
G	90		100		
V	97		117		
C2	100		120		
F2	9		9		
N1	4		4		
M1	13.8		13.8		
D1h6	12		12		
d1	M4x10		M4x10		
L1	17.5		17.5		
h	113		120.2		
T	—		—		
TA.. - TF..					
kg	4.5		6.0		

	TA...- TF...				
	56C		63C		
R	73.5		75		
F	9		9		
e	45		50		
H h8	65		70		
X h8	65		80		
E h8	65		70		
M	M8		M8		
C f8	70		80		
K	85		100		
L	94		100		
S	36		50		
f	9		9		
m	45		55		
c	73.5		80		
N2	6	8	8	8	8
M2	22.8	28.3	28.3	31.3	33.3
D2 H7	20	25	25	28	30
b	73.5		75		
r	45		50		
B	92		111		
G	90		100		
V	97		117		
C2	100		120		
F2	9		9		
N1	4		4		
M1	13.8		13.8		
D1h6	12		12		
d1	M4x10		M4x10		
L1	17.5		17.5		
h	146.6		153.7		
T	229		241.2		
TA.. - TF..					
kg	5.0		6.5		

IEC..B5	TF...																			
	56B					56C					63B					63C				
	56	63	71	80	90	56	63	71	80	90	56	63	71	80	90	56	63	71	80	90
Y	120	140	160	200	200	120	140	160	200	200	120	140	160	200	200	120	140	160	200	200
P	153	156	163	183	183	187	190	197	217	217	160	163	170	190	190	194	197	201	221	221
Q	218	221	228	248	248	252	255	262	282	282	230	233	240	260	260	264	267	271	291	291
kg	4.5	4.5	4.5	4.5	4.5	5.0	5.0	5.0	5.0	5.0	6.0	6.0	6.0	6.0	6.0	6.5	6.5	6.5	6.5	6.5

IEC..B14	TF...																			
	56B					56C					63B					63C				
	56	63	71	80	90	56	63	71	80	90	56	63	71	80	90	56	63	71	80	90
Y	—	—	105	120	140	—	—	105	120	140	—	—	105	120	140	—	—	105	120	140
P	—	—	163	183	183	—	—	197	217	217	—	—	170	190	190	—	—	204	224	224
Q	—	—	228	248	248	—	—	262	282	282	—	—	240	260	260	—	—	274	294	294
kg	—	—	4.5	4.5	4.5	—	—	5.0	5.0	5.0	—	—	6.0	6.0	6.0	—	—	6.5	6.5	6.5

Documento scaricabile dal sito: www.emporiodelcuscinetto.it

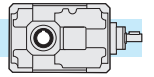

T..56B - T..56C - T..63B - T..63C

2 Riduzioni/Stages/Stufen

3 Riduzioni/Stages/Stufen

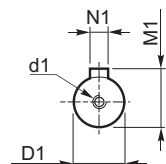
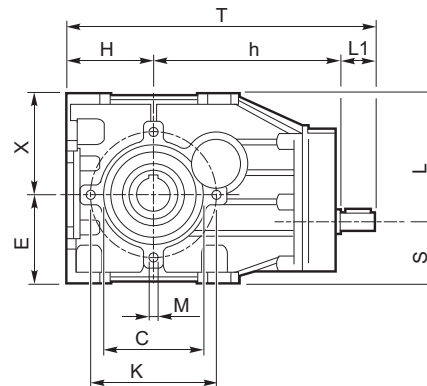
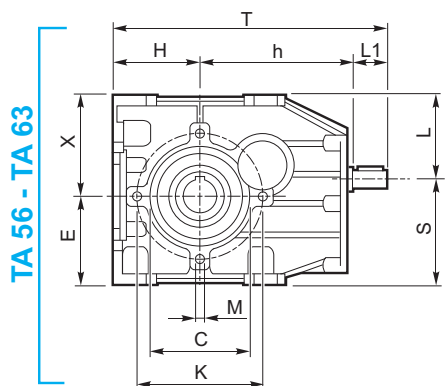
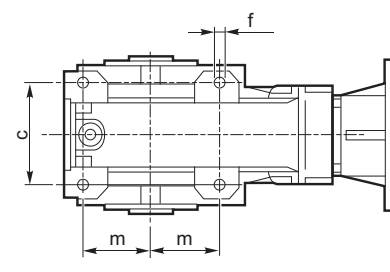
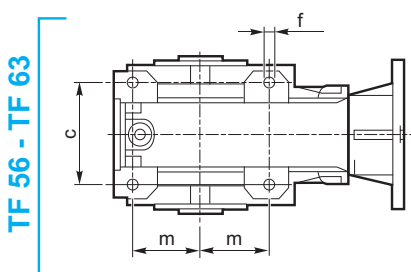
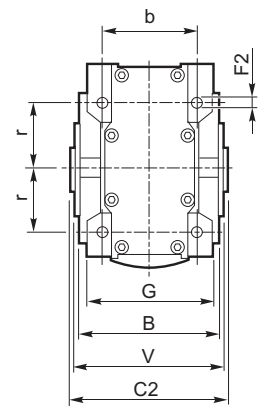
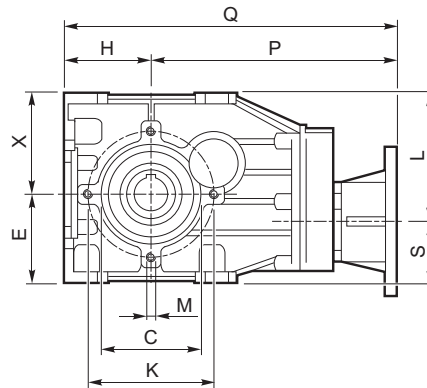
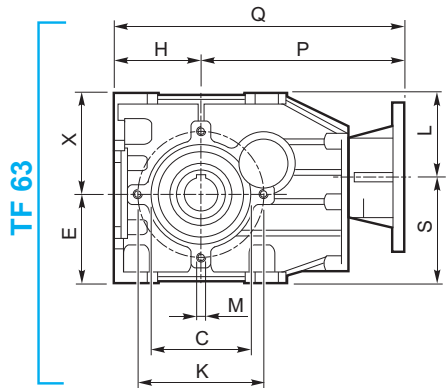
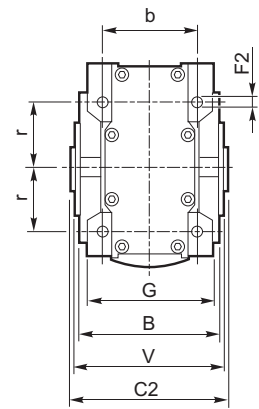
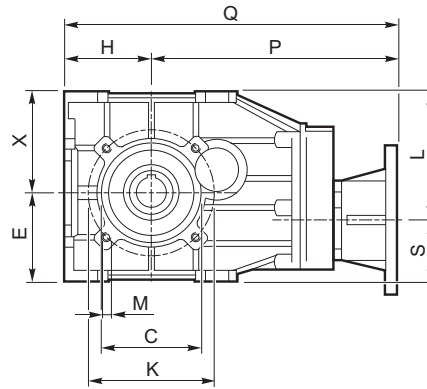
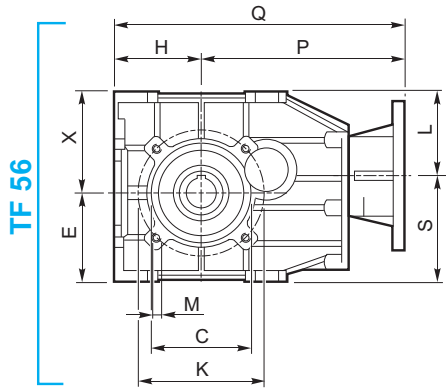
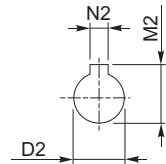
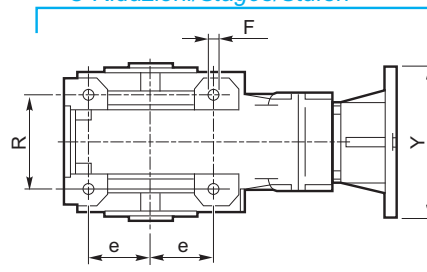
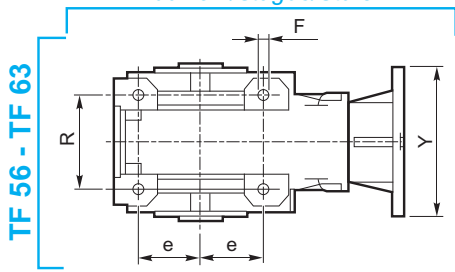

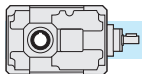

2.10 Dimensioni

2.10 Dimensions

2.10 Abmessungen

TA... - TC... - TF...																
	71B			90B			112B			140B		180B		200B		225B
A	142			180			224			280		360		400		450
a	102			134			166			209		272.5		305		344
a1	—			—			—			—		—		—		—
B	112			127			150			175		215		255		290
b	90			104			125			145		180		210		240
C2	115			130			155			180		220		260		300
D1 h6	14			19			24			28		38		38		48
D2 H7	24	28	30	32	30	35	42	40	45	55	50	70	60	90	80	100
E	206			262			326			407		522.5		585		654
e	38			52			64			82		110		120		140
F	9			11			13			15		17		19		21
f	M8x13			M10x16			M12x19			M14x22		M16x25		M18x35		M18x30
G	122			155			194			244		320		350		400
g	61			77.5			97			122		160		175		200
H	71			90			112			140		180		200		225
h	174			212			262			317		400		422.5		500
l	110			130			160			190		237.5		237.5		296
i	125			159.5			199			249		322.5		360		404
L1	30			40			50			60		80		80		110
O	64			82			102			127		162.5		185		204
T	275			342			424			517		660		702.5		835
t	211			260			322			390		497.5		517.5		631
Z	9			11			13			15		17		22		25

TA..														
kg	12.5		20		34		58		116		165		232	

TC... - TF...														
kg	15.5		25		44		75		136		185		270	

TC...												
	71B				90B				112B			
IEC	63 B5	71 B5	80/90 B5	80 B14	71 B5	80/90 B5	*90 B14	100/112 B5	80/90 B5	100/112 B5	132 B5	
Y	140	160	200	120	160	200	□120 / R73	250	200	250	300	
P	177	184	204	204	220	240	240	250	286	296	318	
p	113	120	140	140	138	158	158	168	184	194	216	
Q	248	255	275	275	310	330	330	340	398	408	430	
q	184	191	211	211	228	248	248	258	296	306	328	

	140B				180B				200B					
IEC	80/90 B5	100/112 B5	132 B5	160/180 B5	100/112 B5		132 B5	160/180 B5	200 B5	100/112 B5		132 B5	160/180 B5	200 B5
Y	200	250	300	350	250		300	350	400	250		300	350	400
P	331	341	363	393	413(i=10-40) / 423(i=50-80)		463(i=10-40) / 473(i=50-80)		435(i=8-40) / 445(i=50-63)		485(i=8-40) / 495(i=50-63)			
p	204	214	236	266	250(i=10-40) / 260(i=50-80)		300(i=10-40) / 310(i=50-80)		250(i=8-40) / 260(i=50-63)		300(i=8-40) / 310(i=50-63)			
Q	471	481	503	533	593(i=10-40) / 603(i=50-80)		643(i=10-40) / 653(i=50-80)		640(i=8-40) / 650(i=50-63)		690(i=8-40) / 700(i=50-63)			
q	344	354	376	406	430(i=10-40) / 440(i=50-80)		480(i=10-40) / 490(i=50-80)		450(i=8-40) / 460(i=50-63)		500(i=8-40) / 510(i=50-63)			

* Flange quadrate / Square flanges / Viereckige Flansche

TF...													
	71B			90B			112B			140B			
IEC	63 B5	71 B5	80/90 B5	71 B5	80/90 B5	100/112 B5	80/90 B5	100/112 B5	132 B5	80/90 B5	100/112 B5	132 B5	160/180 B5
Y	140	160	200	160	200	250	200	250	300	200	250	300	350
P	231	238	259	286	307	317	367	377	398	432	442	463	493
p	167	174	195	204	225	235	265	275	296	305	315	336	366
Q	302	309	330	376	397	407	479	489	510	572	582	603	633
q	238	245	266	294	315	325	377	387	408	445	455	476	506

	180B				200B				225B			
IEC	100/112 B5	132 B5	160/180 B5	200 B5	100/112 B5	132 B5	160/180 B5	200 B5	132 B5	160/180 B5	200 B5	225 B5
Y	250	300	350	400	250	300	350	400	300	350	400	450
P	546	566	596	596	568.5	588.5	618.5	620.5	698	728	728	760
p	393.5	403	433	433	383.5	403.5	433.5	435.5	494	524	524	556
Q	736	746	776	776	768.5	788.5	818.5	820.5	923	953	953	985
q	573.5	583	613	613	583.5	603.5	633.5	635.5	774	749	749	781

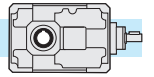

T..71B - T..225B

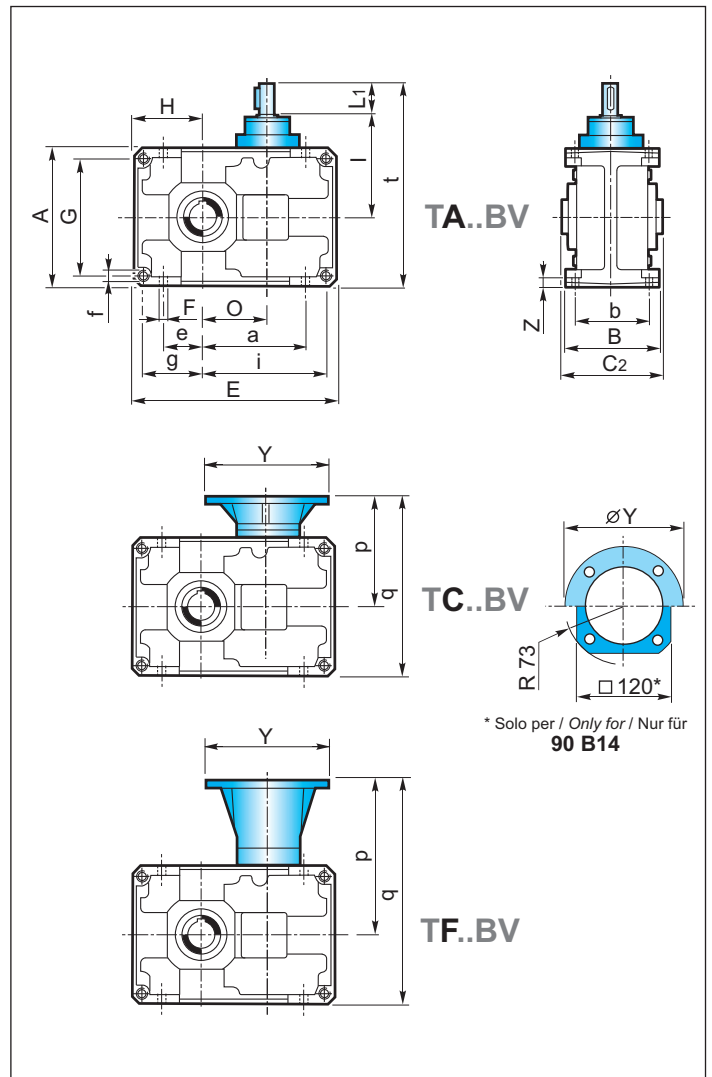
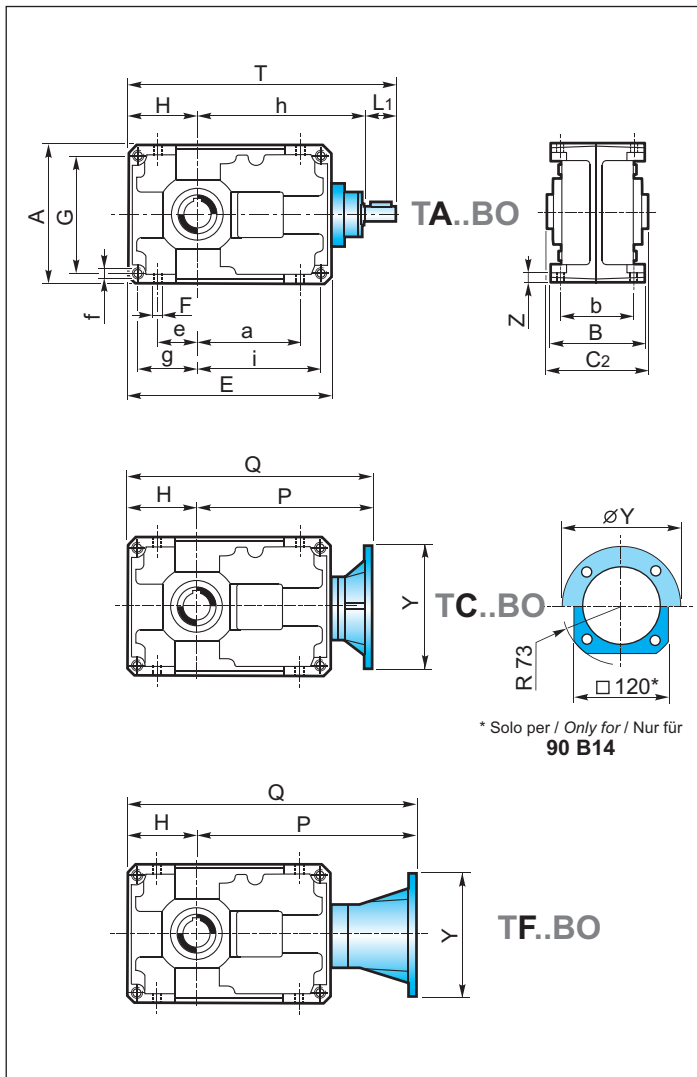

* Solo per / Only for / Nur für
90 B14

* Solo per / Only for / Nur für
90 B14

Albero uscita cavo
Hollow output shaft
Abtriebshohlwelle

Albero entrata
Input shaft
Antriebswelle

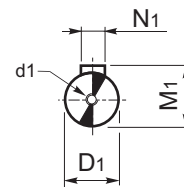
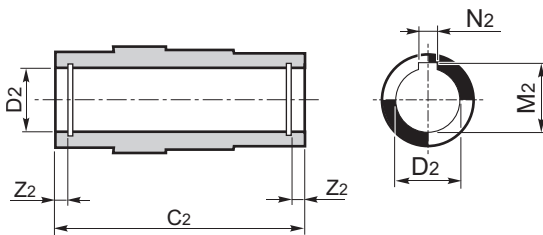

	TA... - TC... - TF...															
	71B			90B			112B			140B		180B		200B		225B
D1 h6	14			19			24			28		38		38		48
d1	M4x15			M8x22			M8x22			M8x22		M10x28		M10x28		M12x34
M1	16			21.5			27			31		41		41		51.5
N1	5			6			8			8		10		10		14
C2	115			130			155			180		220		260		300
D2 H7	24	28	30	32	30	35	42	40	45	55	50	70	60	90	80	100
M2	27.3	31.3	33.3	35.3	33.3	38.3	45.3	43.3	48.8	59.3	53.8	74.9	64.4	95.4	85.4	106.4
N2	8	8	8	10	8	10	12	12	14	16	14	20	18	25	22	28
Z2	—			8.7	8.7	8.4	11	11	11	11.9	11.9	15.4	15.9	18.9	18.9	20

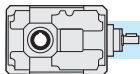

2.10 Dimensioni

2.10 Dimensions

2.10 Abmessungen

TA... - TC... - TF...													
	80C			100C			125C		160C		180C		200C
A	160			200			250		320		360		400
a	82			102			127		162.5		185		204
a1	106			134			169		217		207		277.5
B	127			150			175		215		255		290
b	104			125			145		180		210		240
C2	130			155			180		220		260		300
D1 h6	14			19			24		28		28		38
D2 H7	32	30	35	42	40	45	55	50	70	60	90	80	100
E	306			384			479		609.5		652		766.5
e	42			52			67		90		100		115
F	11			13			15		17		19		21
f	M10x16			M12x19			M14x22		M16x25		M18x35		M18x30
G	135			170			214		280		310		350
g	67.5			85			107		140		155		175
H	80			100			125		160		180		200
h	256			314			389		479.5		502		604
l	110			130			160		190		190		237.5
i	213.5			269			336		429.5		447		541.5
L1	30			40			50		60		60		80
O	146			184			229		289.5		312		366.5
T	366			454			564		699.5		742		884
t	220			270			335		410		430		517.5
Z	11			13			16		17		22		25

TA..									
kg	19		36		66		120	170	260

TC... - TF...									
kg	22		41		76		137	190	295

TC...											
	80C				100C				125C		
IEC	63 B5	71 B5	80/90 B5	80 B14	71 B5	80/90 B5	*90 B14	100/112 B5	80/90 B5	100/112 B5	132 B5
Y	140	160	200	120	160	200	□120 / R 73	250	200	250	300
P	259	266	286	286	322	342	342	352	413	423	445
p	113	120	140	140	138	158	158	168	184	194	216
Q	339	346	366	366	422	442	442	452	538	548	570
q	193	200	220	220	238	258	258	268	309	319	341

	160C				180C				200C			
IEC	80/90B5	100/112 B5	132 B5	160/180 B5	80/90 B5	100/112 B5	132 B5	160/180 B5	100/112 B5	132 B5	160/180 B5	200 B5
Y	200	250	300	350	200	250	300	350	250	300	350	400
P	493	503	525	555	516	526	548	578	617(i=40-160) / 627(i=200-315)	667(i=40-160) / 677(i=200-315)	667(i=40-160) / 677(i=200-315)	667(i=40-160) / 677(i=200-315)
p	204	214	236	266	204	214	236	266	250(i=40-160) / 260 (i=200-315)	300(i=40-160) / 310 (i=200-315)	300(i=40-160) / 310 (i=200-315)	300(i=40-160) / 310 (i=200-315)
Q	653	663	686	715	696	706	728	758	617(i=40-160) / 627(i=200-315)	867(i=40-160) / 877(i=200-315)	867(i=40-160) / 877(i=200-315)	867(i=40-160) / 877(i=200-315)
q	364	374	396	426	384	394	416	446	450(i=40-160) / 460(i=200-315)	500(i=40-160) / 510(i=200-315)	500(i=40-160) / 510(i=200-315)	500(i=40-160) / 510(i=200-315)

* Flange quadrate / Square flanges / Viereckige Flansche

TF...										
	80C			100C			125C			
IEC	63 B5	71 B5	80/90 B5	71 B5	80/90 B5	100/112 B5	80/90 B5	100/112 B5	132 B5	132 B5
Y	140	160	200	160	200	250	200	250	250	300
P	313	320	341	388	409	419	494	494	504	525
p	167	174	195	204	225	235	265	265	275	296
Q	393	400	421	488	509	519	619	619	629	650
q	247	254	275	304	325	335	390	390	400	421

	160C				180C				200C		
IEC	80/90 B5	100/112 B5	132 B5	160/180 B5	80/90 B5	100/112 B5	132 B5	160/180 B5	132 B5	160/180 B5	200 B5
Y	200	250	300	350	200	250	300	350	300	350	400
P	594	604	625	655	617	627	648	678	770	800	802
p	305	315	336	366	305	315	336	366	404	434	436
Q	754	764	785	815	797	807	828	858	970	1000	1002
q	465	475	496	526	485	495	516	546	604	634	636

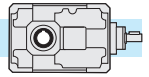

T..80C - T..200C

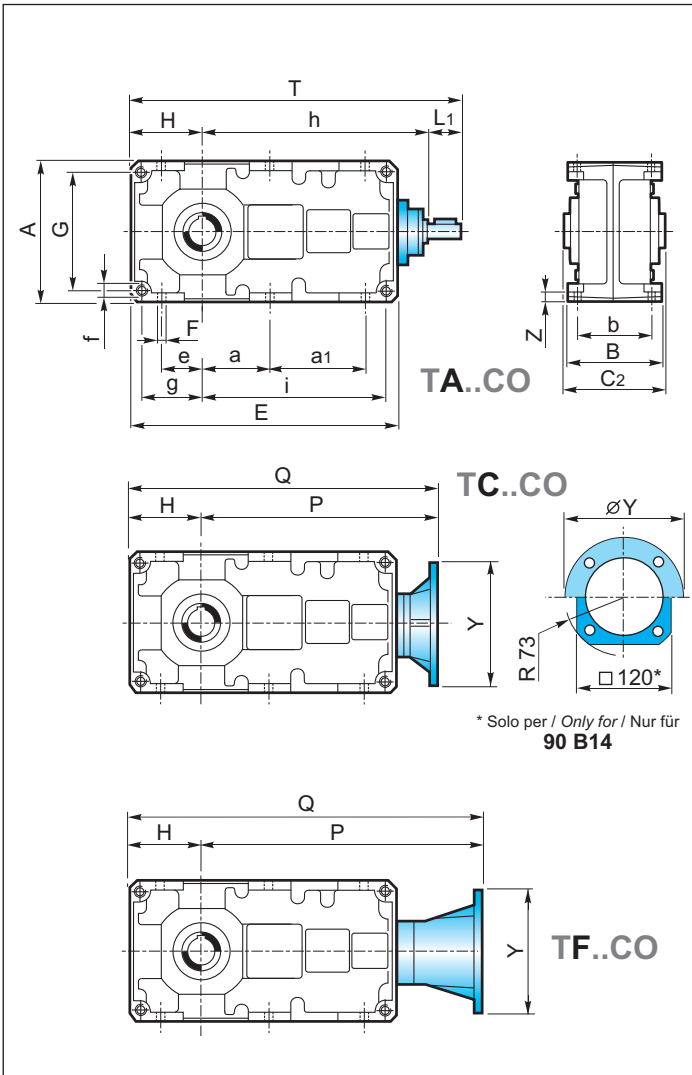

* Solo per / Only for / Nur für
90 B14

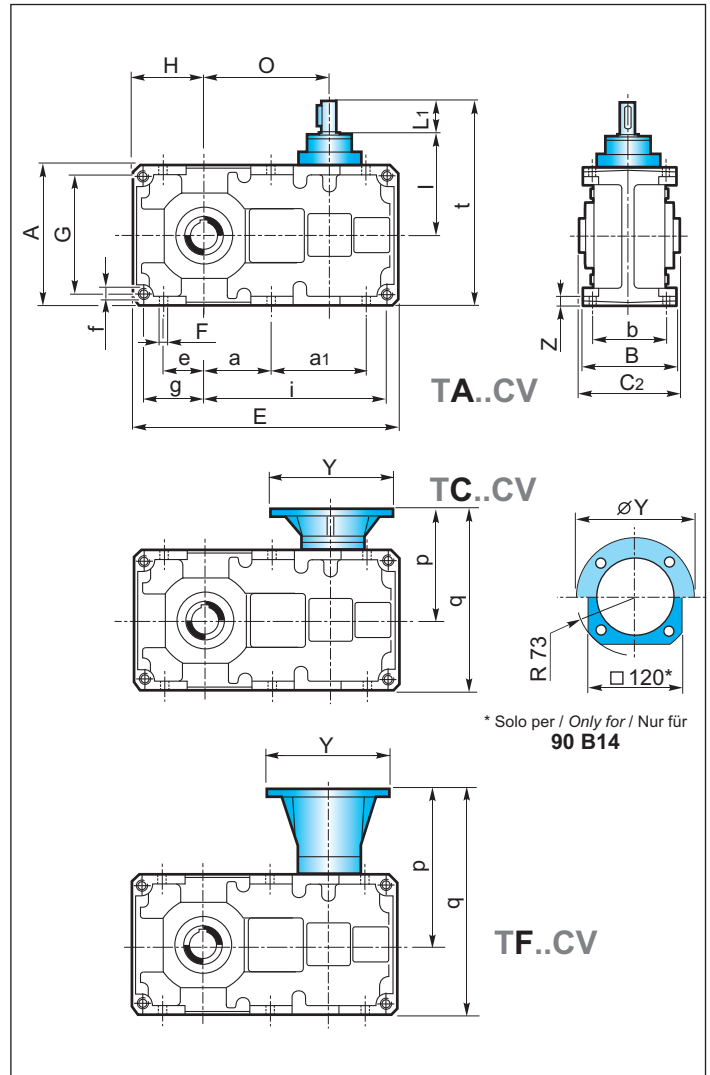

* Solo per / Only for / Nur für
90 B14

Albero uscita cavo
Hollow output shaft
Abtriebshohlwelle

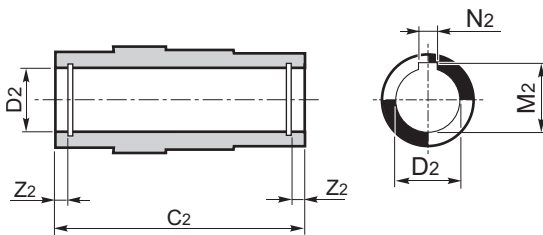

Albero entrata
Input shaft
Antriebswelle

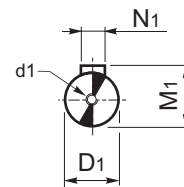

	TA... - TC... - TF...												
	80C			100C			125C		160C		180C		200C
D1 h6	14			19			24		28		28		38
d1	M4x15			M8x22			M8x22		M8x22		M8x22		M10x28
M1	16			21.5			27		31		31		41
N1	5			6			8		8		8		10
C2	130			155			180		220		260		300
D2 H7	32	30	35	42	40	45	55	50	70	60	90	80	100
M2	35.3	33.3	38.3	45.3	43.3	48.8	59.3	53.8	74.9	64.4	95.4	85.4	106.4
N2	10	8	10	12	12	14	16	14	20	18	25	22	28
Z2	8.7	8.7	8.4	11	11	11	11.9	11.9	15.4	15.9	18.9	18.9	20

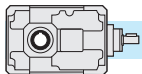

2.11 Accessori

2.11 Accessories

2.11 Zubehör

Albero lento

Output shaft

Abtriebswelle

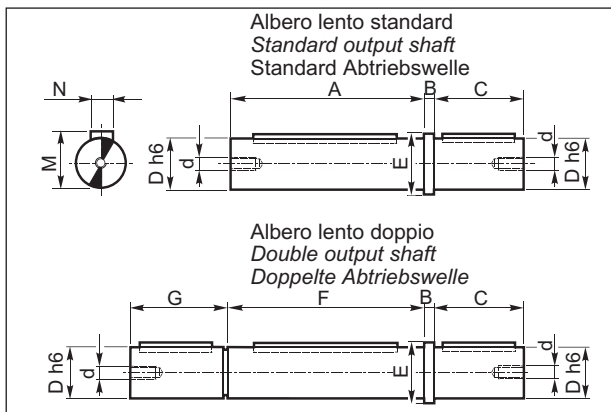

Materiale albero lento: EN 10083 - 1 C40 bonificato
Output shaft material: EN 10083 - 1 C40 tempered
Material der Abtriebswelle: EN 10083 - 1 C40 vergütet

	T										
	56B 56C	63B 63C	71B	90B 80C		112B 100C	140B 125C	180B 160C	200B 180C	225B 200C	
A	100	120	114	129	129	154	154	179	219	259	298
B	5	5	5	6	6	8	8	10	12	15	15
C	40	45	50	60	60	80	80	100	125	140	180
D _{h6}	20	25	24	32	35	42	45	55	70	90	100
d	M8	M8	M8	M8	M8	M10	M10	M10	M12	M16	M18
E	26	32	30	40	43	50	53	65	80	110	118
F	100	120	115	130	—	155	—	180	220	260	300
G	41	46	49	59	—	79	—	99	124	141	178
M	22.5	28	27	35	38	45	48.5	59	74.5	94	106
N	6	8	8	10	10	12	14	16	20	25	28

Albero lento cavo con calettatore

Hollow output shaft with shrink disc

Abtriebshohlwelle mit Schrumpscheibe

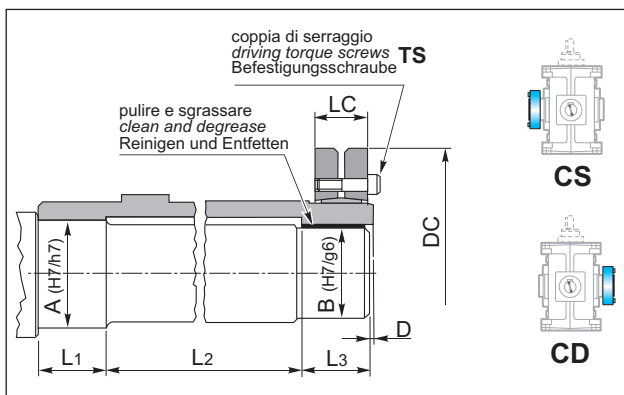

	T									
	56B 56C	63B 63C	71B	90B 80C	112B 100C	140B 125C	180B 160C	200B 180C	225B 200C	
A	27	32	27	37	47	57	72	92	102	
B	25	30	25	35	45	55	70	90	100	
D	2	2	2	2	2	2	2	3	3	
DC	60	72	60	80	100	115	155	188	215	
LC	21.5	23.5	22	26	31	31	39	50	54	
L ₁	32	36	36	39	45	50	60	70	80	
L ₂	61	75	68	82	100	115	143	175	200	
L ₃	32	36	36	39	45	50	60	70	80	
TS _(Nm)	4	12	8	12	12	12	36	59	72	

Kit protezione albero cavo

Hollow shaft protection kit

Schutzvorrichtung für die Hohlwelle

Ad esclusione delle grandezze 56 e 63, a richiesta è possibile predisporre il riduttore con un kit di protezione dell'albero cavo. Tale protezione, essendo dotata di un'opportuna guarnizione, impedisce ad eventuali fluidi, presenti nell'ambiente di lavoro, di venire a contatto con l'albero cavo del riduttore oltre ad impedire il contatto con corpi estranei. Le dimensioni di ingombro sono riportate nella tabella seguente.

On request we can supply a hollow shaft protection kit (except for sizes 56 and 63). The kit features a gasket which prevents any contact between hollow shaft and foreign bodies or fluids existing in the working environment. Over-all dimensions are reported in the following table.

Auf Wunsch ist eine Schutzvorrichtung für die Hohlwelle lieferbar (Größen 56 und 63 ausgenommen). Die Schutzvorrichtung weist eine Dichtung auf, die zur Vermeidung von irgendwelchem Kontakt zwischen Hohlwelle und Fremdkörper oder Flüssigkeiten der Arbeitsumgebung dient. In der folgenden Tabelle wird den Raumbedarf angegeben.

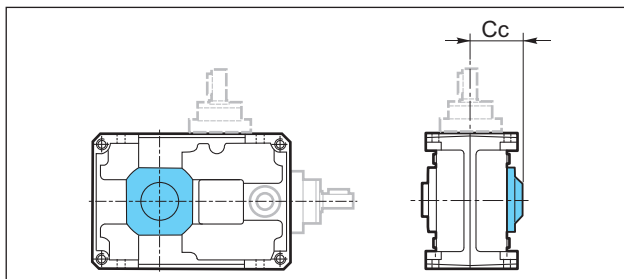

	T						
	71B	90B 80C	112B 100C	140B 125C	180B 160C	200B 180C	225B 200C
Cc	79.5	87	105	120.5	141.5	167.5	191.5

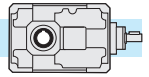

Flangia uscita

Output flange

Abtriebsflansch

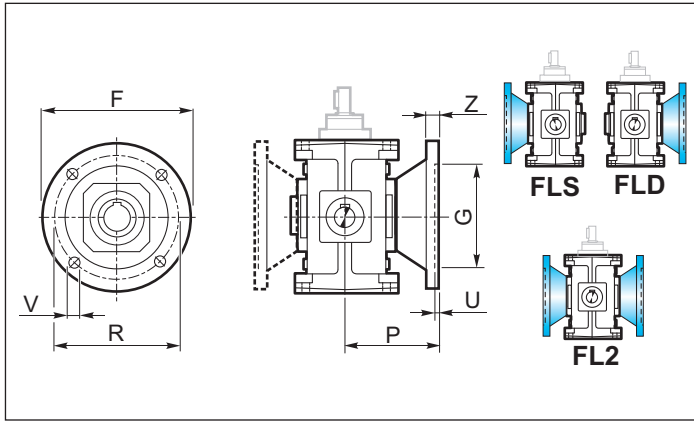

	T							
	56B 56C	63B 63C	71B	90B 80C	112B 100C	140B 125C	180B 160C	200B 180C
F	140	160	160	200	250	300	350	400
G_{G6}	95	110	110	130	180	230	250	300
R	115	130	130	165	215	265	300	350
P	82	91.5	87	100	125	150	180	215
U	5	5	4	4.5	5	5	6	6
V	9	9	12	12	14	16	18	20
Z	15	10	10	12	16	20	25	30
kg	0.5	0.5	2	3.2	5	8	12.5	24

Braccio di reazione

Torque arm

Drehmomentstütze

56B - 56C

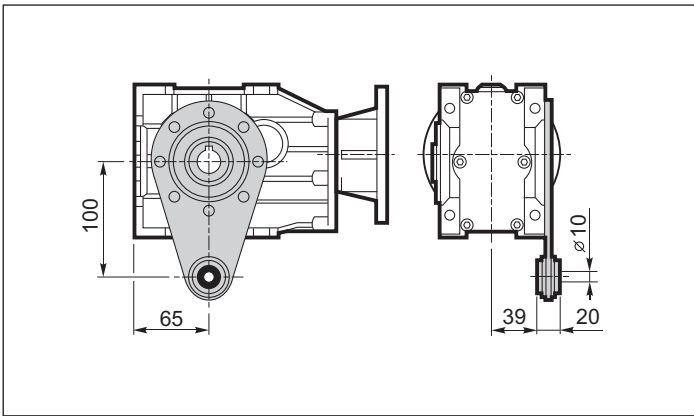

63B - 63C

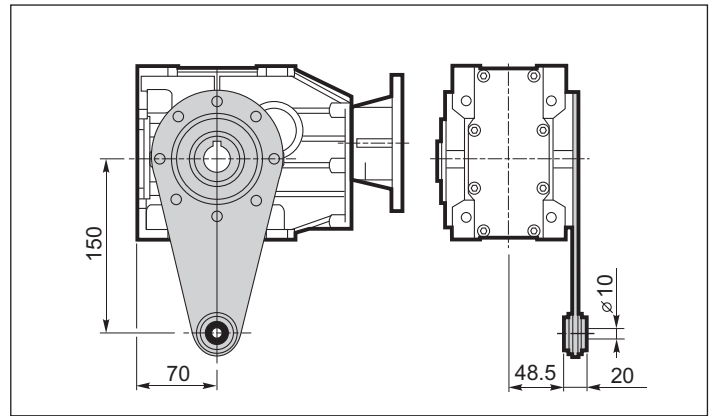

71B - 225B

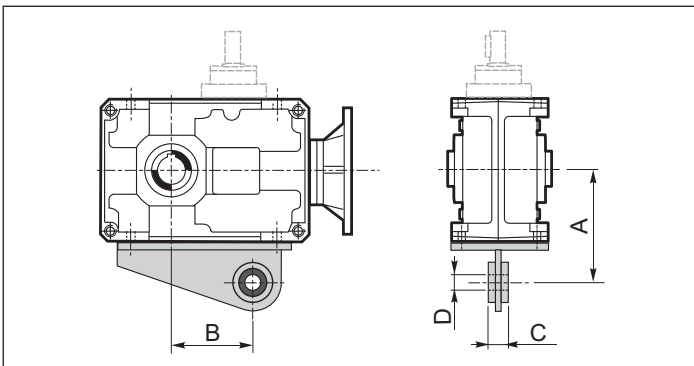

80C - 200C

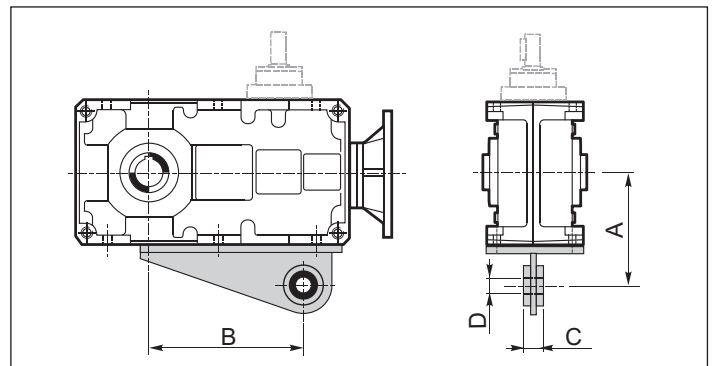

	T						
	71B	90B	112B	140B	180B	200B	225B
A	123	140	172	205	260	300	325
B	84	116	144	189	247.5	280	319
C	25	25	30	30	35	45	45
D	20	20	25	25	35	40	40

	T					
	80C	100C	125C	160C	180C	200C
A	130	160	190	240	280	300
B	170	214	276	354.5	367	456.5
C	25	30	30	35	45	45
D	20	25	25	35	40	40

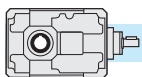

Dispositivo antiritorno

Il riduttore ad assi ortogonali presenta valori di rendimento statico (e dinamico) molto elevati: per questo motivo non è garantita spontaneamente l'irreversibilità statica. L'irreversibilità statica si realizza quando, a riduttore fermo, l'applicazione di un carico all'albero lento non pone in rotazione l'asse entrante. Pertanto, per garantire l'irreversibilità del moto, a riduttore fermo, occorre predisporre il riduttore stesso con un opportuno dispositivo antiritorno, fornibile a richiesta tranne che sulle grandezze T56 e T63.

Tale dispositivo permette la rotazione dell'albero lento solo nel senso desiderato, da specificare all'atto dell'ordine.

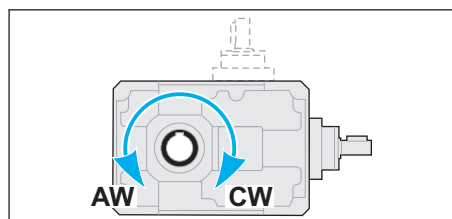

Backstop device

Bevel helical gearboxes feature quite high values of static (and dynamic) efficiency: for this reason spontaneous static irreversibility is not guaranteed. Static irreversibility, with motionless gearbox, occurs when the application of a load on the output shaft does not cause rotation of the input axis. In order to guarantee motion irreversibility, with motionless gearbox, it is necessary to fit a backstop device, which is available on request, except for sizes 56 and 63. The backstop device enables rotation of the output shaft only in the required direction, which is to be specified when ordering.

Rücklaufsperr

Kegelstirnradgetriebe weisen sehr hohen statischen (und dynamischen) Wirkungsgrad: deshalb wird keine spontane statische Irreversibilität garantiert. Statische Irreversibilität bei stillstehenden Getriebe hat man, wenn die Applikation einer Last auf die Abtriebswelle keine Drehung der Antriebswelle verursacht. Um Irreversibilität der Bewegung bei stillstehendem Getriebe zu sichern, soll eine Rücklaufsperr montiert werden. Die Rücklaufsperr wird auf Wunsch geliefert (Größen 56 und 63 ausgenommen).

Die Rücklaufsperr ermöglicht, dass die Abtriebswelle nur in der gewünschten Richtung dreht (gewünschte Richtung beim Bestellen angeben).

CW Rotazione oraria
Clockwise rotation
Im Uhrzeigersinn

AW Rotazione antioraria
Anti-clockwise rotation
Gegen den Uhrzeigersinn

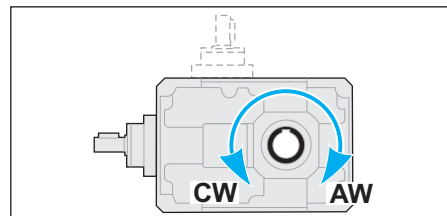

Un esempio tipico di applicazione in cui è richiesto l'impiego del dispositivo antiritorno è il caso in cui un riduttore venga utilizzato per la movimentazione di un nastro trasportatore inclinato, con il carico che si muove in salita. In caso di arresto dell'impianto, a causa del peso proprio del carico movimentato ed in assenza di sistemi di sicurezza, il nastro tenderebbe spontaneamente ad invertire il moto (moto retrogrado) riportando il materiale trasportato al punto di partenza. Il dispositivo antiritorno presente nel riduttore si oppone a questo fenomeno mantenendo il nastro fermo.

Nel caso in cui sia presente il dispositivo antiritorno è raccomandato l'utilizzo di olio lubrificante sintetico, classe di viscosità ISO 150.

A typical example of application which requires a backstop device is when the gearbox is used for moving a sloping conveyor belt with the load moving upwards. In case the plant stops working, if there are no safety devices, because of the load weight the conveyor would tend to invert the motion direction (backward motion), thus bringing the transported material back to starting point. The backstop device on the gearbox prevents backward motion by keeping the conveyor motionless.

In gearboxes with backstop device we recommend synthetic lubricant, viscosity class ISO150.

Ein typisches Beispiel von Anwendung der Rücklaufsperr ist, wenn das Getriebe für die Bewegung eines schiefen Förderbands benutzt wird, wobei die Last ansteigend bewegt wird. Im Falle von Stehenbleiben der Anlage und Abwesenheit von Sicherheitsvorrichtungen würde sich das Förderband spontan wegen des Lastgewichts rückwärts bewegen und das transportierte Material zurück zum Ausgangspunkt bringen. Die Rücklaufsperr hindert die Rückwärtsbewegung und hält das Förderband fest.

Beim Einsatz einer Rücklaufsperr ist die Verwendung von synthetischen Öl mit Viskositätsklasse ISO 150 empfohlen.

Nella tabella seguente (tab. 3) sono indicati i valori dei momenti torcenti nominali massimi (T_{2Mmax}), riferiti all'albero uscita, garantiti dal dispositivo di antiritorno, per ogni rapporto di riduzione e per ogni grandezza di riduttore. Se, in corrispondenza dell'albero lento, viene applicata una coppia maggiore di quella indicata, l'irreversibilità del moto non è più garantita.

Questi valori di coppia non sono da confondere con quelli riportati nella tabella riguardante i dati tecnici dei riduttori. Infatti, si noti come in tabella siano stati messi in evidenza i valori di coppia garantiti (in uscita) dal dispositivo antiretro che risultano essere minori dei massimi valori di coppia motrice trasmissibili, con fattore di servizio $F_s = 1$, dal riduttore.

The following table (tab..3) shows the max. rated torques (T_{2Mmax}) at gearbox output guaranteed by the backstop device, for each ratio and each gearbox size. If a higher torque is applied at gearbox output, motion irreversibility is no longer guaranteed.

These torque values are not to be confused with the values reported in the gearbox specifications tables.

Please note that the torque values guaranteed (at output) by the backstop device are lower than the max. driving torque values transmissible by the gearbox, with service factor $F_s = 1$.

In der folgenden Tabelle (Tab. 3) werden die max. Nenndrehmomente am Abtrieb angegeben (T_{2Mmax}), die die Rücklaufsperr je nach Untersetzungsverhältnis und Getriebegröße garantiert. Falls am Abtrieb ein höheres Drehmoment eingesetzt wird, dann ist die Irreversibilität der Bewegung nicht mehr garantiert.

Diese Drehmomente sind nicht mit den Werten zu verwechseln, den in der Tabelle der technischen Daten der Getriebe angegeben werden.

Die von Rücklaufsperr (am Abtrieb) garantierten Drehmomente sind niedriger als die von Getriebe übersetzbaren max. Drehmomente, unter Berücksichtigung eines Betriebsfaktors $F_s = 1$.

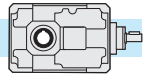

Coppia massima garantita in uscita dal dispositivo antiritorno
Max. output torque guaranteed by the backstop device
Von Rücklaufsperr garantierten max. Abtriebsdrehmoment

Tab. 3

T	in													
	5*	6.3*	7*	8	10	12.5	16	20	25	31.5	40	50	63	80
	T_{2M} max [Nm]													
71B	—	—	—	—	213	272	325	213	271	325	421	272	325	421
90B	148	204	—	—	333	424	508	333	424	508	657	424	508	657
112B	326	—	—	—	733	934	1118	733	933	1119	1446	933	1118	1446
140B	—	—	1038	—	1547	1969	2358	1547	1968	2359	3051	1968	2359	3050
180B	—	—	—	—	3009	3831	4588	3009	3829	4589	5935	3829	4589	5934
200B	—	—	—	5937	7607	9189	11399	12873	9190	11402	12875	11401	12875	—
225B	—	—	—	9856	11829	14538	9858	11838	14536	14537	17800	—	—	—

T	in												
	40	50	63	80	100	125	160	200	250	315	400	500	630
	T_{2M} max [Nm]												
80C	—	1086	1301	1656	1086	1301	1656	1985	1301	1656	1985	2567	3319
100C	—	1697	2033	2588	1697	2033	2588	3101	2033	2588	3101	4010	5186
125C	—	3733	4474	5694	3733	4473	5693	6822	4473	5693	6822	8822	11410
160C	—	7874	9435	12008	7873	9435	12008	14388	9434	12008	14388	18607	24064
180C	—	7874	9435	12008	7873	9435	12008	14388	9434	12008	14388	18607	24064
200C	12511	15024	18453	22586	15023	18450	22594	15024	18452	22594	—	—	—

* Rapporti speciali / Special ratios / Sonderverhältnisse

Valori di coppia garantiti / Torque values guaranteed / Garantierten Drehmomente

Verifica del Dispositivo antiritorno

Dopo aver correttamente selezionato il riduttore (v. pag. 4), occorre verificare se il valore del momento torcente T_{2M}max garantito all'asse uscita del riduttore dal dispositivo antiritorno, considerate le reali condizioni di esercizio, è sufficiente a garantire il buon funzionamento dell'applicazione.

Deve pertanto essere verificata la seguente relazione:

Check out of the backstop device

After having selected the gearbox (see page 4) it is necessary to check whether the max. output torque T_{2M}max guaranteed by the backstop device, in view of the actual operating conditions, is sufficient to ensure the good functioning of the application. The following equation has to be checked out:

Prüfung der Rücklaufsperr

Nach der Wahl des Getriebes (s. S. 4) soll es sichergestellt werden, dass das von der Rücklaufsperr garantierten Abtriebsdrehmoment T_{2M}max genug ist, damit der korrekten Ablauf der Applikation unter Berücksichtigung der wirklichen Betriebsbedingungen gewährleistet wird. Die folgende Relation ist festzustellen:

$$T_{2M}max \geq T_{2NOM} \cdot fc \cdot fa \cdot ft \quad (1)$$

Dove:

T_{2NOM} [Nm]: è il momento torcente che deve essere garantito all'asse uscita del riduttore, nell'istante in cui viene interrotta la trasmissione del moto, affinché sia soddisfatta la condizione di irreversibilità del moto. T_{2NOM} dipende dalle specifiche dell'applicazione e deve essere valutato volta per volta.

fc: fattore di carico

- fc=1 in caso di funzionamento regolare
- fc=1.3 in caso di funzionamento con urti moderati
- fc=1.8 in caso di funzionamento con forti urti

Where:

T_{2NOM} [Nm]: is the torque that must be guaranteed at gearbox output when motion transmission is stopped, in order that motion irreversibility is ensured. T_{2NOM} depends on application features and should be assessed each time.

fc: load factor

- fc=1 in case of standard operation
- fc=1.3 in case of operation with moderate shocks
- fc=1.8 in case of operation with heavy shocks

Dabei ist:

T_{2NOM} [Nm]: Drehmoment, das am Getriebebetrieb garantiert werden muss, wenn die Übertragung der Bewegung stoppt, damit Irreversibilität gewährleistet wird. T_{2NOM} hängt von der Merkmale der Applikation, d. h. T_{2NOM} muss jeweils bewertet werden.

fc: Last-Faktor

- fc=1 bei Standardbetrieb
- fc=1.3 bei Betrieb mit mäßigen Stößen
- fc=1.8 bei Betrieb mit starken Stößen

NOTA:

Per funzionamento regolare si intende il caso in cui il dispositivo antiritorno, in attesa della ripresa della normale attività del riduttore, mantiene la macchina ferma. Se invece, nel momento in cui il dispositivo antiritorno è azionato (quindi il riduttore è fermo), il carico in uscita aumenta di intensità si possono avere degli urti (moderati o forti).

REMARK:

standard operation means that the backstop device keeps the machine still, whilst awaiting the restart of gearbox operation. On the contrary, in case the backstop device is enabled (therefore the gearbox is motionless) and the output load gets heavier, moderate or heavy shocks might occur.

ANMERKUNG:

Standardbetrieb bedeutet, dass (in Erwartung des Wiederbeginns des Getriebebetriebs) die Rücklaufsperr die Maschine stoppt. Dagegen, falls die Rücklaufsperr betätigt ist (deshalb bewegt sich das Getriebe nicht) und die Last am Abtrieb stärker wird, dann können mäßigen oder starken Stößen entstehen.

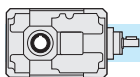

fa: fattore di applicazione, ricavabile dalla seguente tabella (tab. 4) in funzione del numero di inserzioni/ora e dal numero di ore di funzionamento al giorno del riduttore.

fa: application factor, as shown in the following table (tab. 4), depending on the number of backstop device insertions per hour and the number of gearbox operating hours per day.

fa: Anwendungsfaktor, wie es in der folgenden Tabelle (tab. 4) angegeben wird. Der Anwendungsfaktor hängt von Zahl der Einschaltungen der Rücklaufsperrre pro Stunde und von Betriebsstunden des Getriebes pro Tag ab.

Tab. 4

h/gg - h/d - St./Tag	n° INSERZIONI / h - INSERTIONS / H - NR. EINSCHALTUNGEN / STUNDE					
	2	4	8	16	32	63
8	1	1	1.1	1.2	1.3	1.4
16	1.3	1.3	1.4	1.5	1.6	1.7
24	1.5	1.5	1.6	1.7	1.8	1.9

ft: fattore di temperatura ricavabile dalla seguente tabella (tab.5) in funzione della temperatura ambiente di funzionamento.

ft: temperature factor, as shown in the following table (tab. 5) depending on ambient temperature during gearbox operation.

ft: Temperaturfaktor, wie es in der folgenden Tabelle (tab. 5) angegeben wird. Der Temperaturfaktor hängt von der Umgebungstemperatur während Getriebebetriebs ab.

Tab. 5

Tamb (°C)	-20°	-10°	0°	10°	20°	30°	40°	50°
ft	1.2	1.15	1.1	1.05	1	1.03	1.05	1.10

Se la relazione (1) a pag. 25 non risulta essere verificata si prenda in considerazione la possibilità o di variare il rapporto di riduzione, individuando una alternativa migliore, o di passare alle grandezze di riduttori successive.

If the result of the calculation does not correspond to the equation (1) at page 25, either the ratio has to be modified or a bigger size of gearbox has to be selected.

Falls das Resultat nicht der Relation (1) entspricht (Seite 25), soll entweder das Untersetzungsverhältnis oder die Größe des Getriebes geändert werden.

Nel caso in cui il riduttore, provvisto di dispositivo antiritorno, si trovi ad operare ad una temperatura ambiente minore di 0°C il riduttore può essere fornito, a seconda del rapporto di riduzione, in esecuzione speciale (con camera stagna) così da migliorare il funzionamento del dispositivo. Per quanto riguarda quest'ultima soluzione si contatti il servizio tecnico Tramec.

If the ambient temperature is below 0°C, the gearbox with backstop device can be supplied in the special execution (with tight chamber) which improves the functioning of the backstop device. Please contact Tramec Technical Dept. for further information.

Liegt die Umgebungstemperatur unter 0°C, wird es empfohlen, die Sonderausführung des Getriebes (mit Dichtkammer) zu benutzen, damit die Rücklaufsperrre am besten funktioniert. Für weitere Auskünfte darüber soll man sich mit Tramec technischen Büro in Verbindung setzen.

Dimensioni riferite alla versione con antiretro

Dimensions of the version with backstop device

Abmessungen der Version mit Rücklaufsperrre

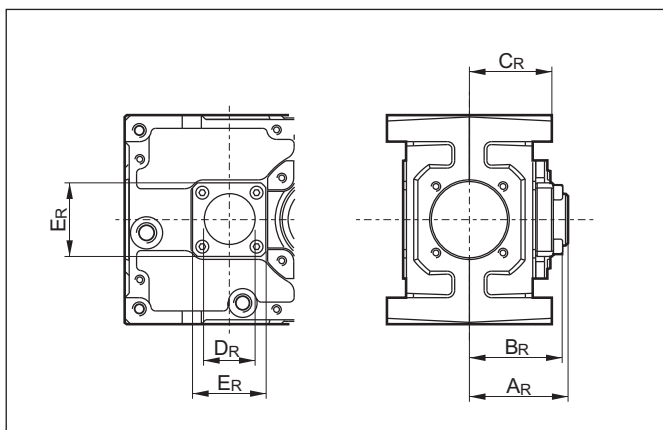

	AR	BR	CR	DR	ER
T 71B	67	63	56	35	50
T 80C	67	63	63.5	45	60
T 90B	73	68	63.5	45	60
T 100C	71.5	70	75	55	80
T 112B	90	83	75	55	80
T 125C	86.5	96.5	87.5	60	90
T 140B	108	95	87.5	70	90
T 160C	106.5	101	107.5	70	100
T 180B	122	113	107.5	80	110
T180C	110.5	110	127.5	70	100
T200B	163	137.5	127.5	90	160
T 200C	125	124	145	90	130
T 225B	169	147	145	110	155

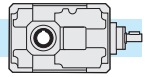

2.12 Giochi angolari

Bloccando l'albero di entrata, il gioco viene misurato sull'albero uscita ruotandolo nelle due direzioni ad applicando la coppia strettamente necessaria a creare il contatto tra i denti degli ingranaggi, al massimo pari al 2% della coppia massima garantita dal riduttore (T_{2M}).

Nella tabella seguente sono riportati i valori indicativi del gioco angolare (in minuti di angolo) per quanto riguarda il montaggio normale ed i valori ottenibili con una registrazione più precisa. Quest'ultima esecuzione è da utilizzare solo in caso di reale necessità in quanto potrebbe comportare un leggero aumento della rumorosità e rendere meno efficace l'azione dell'olio lubrificante.

2.12 Angular backlash

After having blocked the input shaft, the angular backlash can be measured on the output shaft by rotating it in both directions and applying the torque which is strictly necessary to create a contact between the teeth of the gears. The applied torque should be at most 2% of the max. torque guaranteed by the gearbox. (T_{2M}).

The following table reports the approximate values of the angular backlash (in minutes of arc) referred to standard mounting and mounting with a more precise adjustment. The latter solution should be adopted only in case of necessity because it may raise the noise level and lessen the action of the lubricant.

2.12 Winkelspiel

Nachdem die Antriebswelle blockiert worden ist, darf das Winkelspiel auf die Abtriebswelle bemessen werden. Dabei soll die Abtriebswelle in beiden Richtungen gedreht werden und ein Drehmoment ausgeübt werden, das zur Entstehung eines Kontaktes zwischen den Zähnen genügt. Das ausgeübte Drehmoment soll höchstens 2% des max. von Getrieben garantierten Drehmoment (T_{2M}) sein.

Die folgende Tabelle weist die Näherungswerte des Winkelspiels (in Bogenminuten) für Standardmontage und Montage mit präziser Regulierung. Die präzisere Lösung darf nur im Notfall angewendet werden, weil infolgedessen das Geräuschpegel zunimmt und die Wirkung des Schmiermittels abnimmt.

Gioco angolare / Backlash / Winkelspiel (1')		
	Montaggio normale Standard mounting Standardmontage	Montaggio con gioco ridotto Mounting with reduced backlash Montage mit reduziertem Winkelspiel
2 stadi/stages/stufig	16/20	12/15
3 stadi/stages/stufig	20/25	15/17

2.13 Lubrificazione

I riduttori ad assi ortogonali (ad esclusione dei tipi TF56 e TF63, con lubrificazione a vita) sono forniti predisposti per lubrificazione a olio e muniti dei tappi di carico, livello e scarico olio.

Si raccomanda di precisare sempre la posizione di montaggio desiderata in fase di ordine.

POMPA DI LUBRIFICAZIONE.

Una pompa per lubrificazione forzata dei cuscinetti superiori è fornita a richiesta sulle grandezze 112, 125, 140, 160, 180, 200 e 225 nella posizione di montaggio VA.

Nelle posizioni di montaggio in cui sono presenti cuscinetti posti al di sopra del livello dell'olio lubrificante è prevista l'applicazione di grasso speciale su tali cuscinetti per migliorarne la lubrificazione. E' possibile dotare gli stessi cuscinetti di un anello metallico (nylos) con la funzione di contenimento del grasso e, di conseguenza, di prolungare l'effetto nel tempo. Questa soluzione viene fornita su specifica richiesta.

2.13 Lubrication

Bevel helical gearboxes (except for TF56 and TF63 which are lubricated for life) require oil lubrication and are equipped with filler, level and drain plugs.

The mounting position should always be specified when ordering the gearbox..

OIL PUMP.

A pump for forced lubrication of the upper bearings is supplied on request for sizes 112, 125, 140, 160, 180, 200 and 225 in the VA mounting position.

Depending on the mounting position, the bearings may be lodged above the lubricant level. In this case it is necessary to apply special grease on the bearings in order to improve their lubrication. A metallic ring (nylos) can be fitted on the bearings it keeps the grease in place thus prolonging the action. It is supplied on specific request.

2.13 Schmierung

Die Kegelstirradgetriebe sind für die Ölschmierung mit Einfüll-, Ölstand- und Ablassstopfen versehen.

Bei der Bestellung ist immer die gewünschte Montageposition anzugeben.

ÖLPUMPE.

Eine Pumpe für die Zwangsschmierung der oberen Lager kann auf Wunsch bei den Größen 112, 125, 140, 160, 180, 200 und 225 in der Montageposition VA geliefert werden.

Abhängig von der Einbaulage kann es sein, dass die Lager über den Ölstand liegen. In dem Fall wird Sonderfett auf die Lager geschmiert, um deren Schmierung zu verbessern. Ein metallischer Ring (nylos) für die Lager darf auf Wunsch geliefert werden: er hält das Fett fest und verlängert die Wirkung.

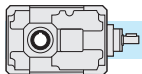

Posizione di montaggio e quantità di lubrificante (litri)

I quantitativi di olio riportati nelle varie tabelle sono indicativi e riferiti alle posizioni di lavoro indicate e considerando le condizioni di funzionamento a temperatura ambiente e velocità in ingresso di 1400 min⁻¹. Per condizioni di lavoro diverse da quelle sopra riportate contattare il servizio tecnico.

Mounting positions and lubricant quantity (liters)

The oil quantities stated in the tables are approximate values and refer to the indicated working positions, considering operating conditions at ambient temperature and an input speed of 1400 min⁻¹. Should the operating conditions be different, please contact the technical service.

Montageposition und Ölmenge (liter)

Die in der Tabellen angegebenen Daten sind Richtwerte. Die Ölmengen beziehen sich auf die angegebenen Betriebsposition. Dabei werden Betrieb bei Umgebungstemperatur und Antriebsdrehzahl von 1400 min⁻¹ berücksichtigt. Falls die Betriebsbedingungen anders sind, dann ist das technische Büro zu befragen.

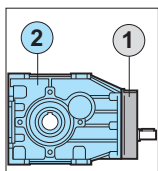
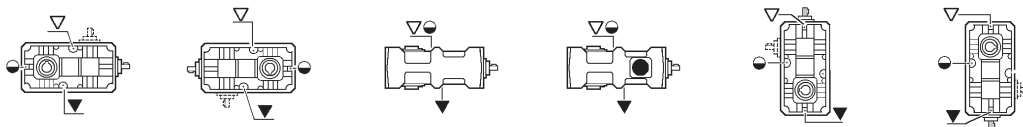

T	B3	B8	B6	B7	VA	VB
② 56B		0.30			0.40	0.30
① 56C			0.05			
② 56C		0.30			0.40	0.30
② 63B		0.35			0.45	0.35
① 63C			0.05			
② 63C		0.35			0.45	0.35
71B	0.6		0.7	0.5		0.8
80C	1.1		1.5	1.3		1.5
90B	1.0		1.4	1.2		1.3
100C	2.0		2.6	2.3		2.8
112B	1.8		2.6	2.3		2.4
125C	3.8		4.8	4.5		5.0
140B	3.6		4.6	4.3		4.3
160C	7.0		9.2	8.7		10.0
180B	7.5		9.7	9.2		8.0
180C	9.5		14.0	13.0		15.5
200B	12.5		15.0	14.0		17.5
200C	13.5		19.0	18.0		19.5
225B	14.5		19.0	18.0		18.7

* Nella posizione di montaggio B6 è previsto un tappo di sfiato con asta di livello.
 * In mounting position B6 the breather plug is fitted with dipstick.
 * Für die B6 Version ist eine Entlüftungsschraube mit Ölstandsanzeiger vorausgesehen.

Posizione morsetti

Terminal board position

Lage der Klemmenkaste

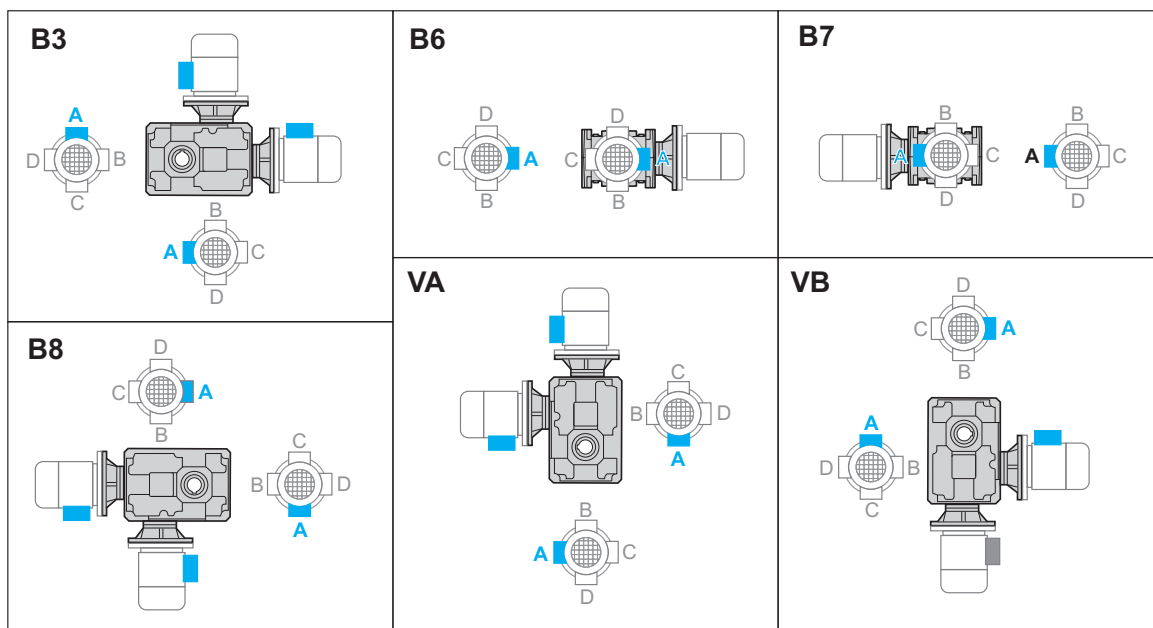

N.B. Se non diversamente specificato, il motore verrà fornito con la morsetti in posizione A.

N.B. Unless o otherwise agreed, the motor will be supplied with the terminal board in position A.

ANMERKUNG: Ausser wenn anders angegeben, wird der Motor mit Klemmenkaste in der A Position geliefert.

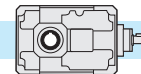

2.14 Carichi radiali e assiali (N)

Le trasmissioni effettuate tramite pignoni per catena, ruote dentate o pulegge generano delle forze radiali (F_R) sugli alberi dei riduttori. L'entità di tali forze può essere calcolata con la formula:

2.14 Radial and axial loads (N)

Transmissions implemented by means of chain pinions, wheels or pulleys generate radial forces (F_R) on the gear unit shafts. The entity of these forces may be calculated using the following formula:

2.14 Radial- und Axialbelastungen (N)

Antriebe mit Kettenritzel, Zahnradern oder Riemenscheiben erzeugen radiale Kräfte (F_R) an den Wellen der Untersetzungsgetriebe. Das Ausmaß dieser Kräfte kann nach folgender Formel berechnet werden:

$$F_R = \frac{K_R \cdot T}{d} \text{ [N]}$$

dove:
 T = Momento torcente [Nm]
 d = Diametro pignone o puleggia [mm]
 K_R = 2000 per pignone per catena
 = 2500 per ruote dentate
 = 3000 per puleggia con cinghie a V

where :
 T = torque [Nm]
 d = pinion or pulley diameter [mm]
 K_R = 2000 for chain pinion
 = 2500 for wheel
 = 3000 for V-belt pulley

dabei ist:
 T = Drehmoment [Nm]
 d = Kettenritzel- bzw. Riemenscheibendurchmesser [mm]
 K_R = 2000 bei Kettenritzel
 = 2500 bei Zahnrad
 = 3000 bei Riemenscheibe mit Keilriemen

I valori dei carichi radiali e assiali generati dall'applicazione debbono essere sempre minori o uguali a quelli ammissibili indicati nelle tabelle.

The values of the radial and axial loads generated by the application must always be lower than or equal to the admissible values reported in the tables.

Die Werte der Radial- und Axialbelastungen, die durch die Anwendung hervorgerufen werden, dürfen nicht über den in den Tabellen angegebenen zulässigen Werten liegen.

$$F_R \quad Fr_{1-2}$$

Se il carico radiale sull'albero non è applicato a metà della sporgenza dell'albero, il valore del carico ammissibile deve essere valutato utilizzando la formula che si riferisce ad Fr_{y1-2} , in cui i valori di a , b e Fr_{1-2} sono riportati nelle tabelle relative ai carichi radiali. Nel caso di alberi bisporgenti il valore del carico applicabile a ciascuna estremità è uguale ai 2/3 del valore di tabella, purchè i carichi applicati siano uguali di intensità e direzione ed agiscano nello stesso senso. Diversamente contattare il servizio tecnico.

Should the radial load affect the shaft not at the half-way point of its projection but at a different point, the value of the admissible load has to be calculated using the Fr_{y1-2} formula: a , b and Fr_{1-2} values are reported in the radial load tables. With regard to double-projecting shafts, the load applicable at each end is 2/3 of the value given in the table, on condition that the applied loads feature same intensity and direction and that they act in the same direction. Otherwise please contact the technical department.

Falls die Radialbelastungen nicht in dem Mittelpunkt der herausragenden Welle sondern in einem anderen Punkt wirken, soll die zulässige Belastung mit der Formel bezüglich Fr_{y1-2} kalkuliert werden: a , b und Fr_{1-2} Werte sind aus der Tabelle der Radialbelastungen zu entnehmen. Bei zweifach vorstehenden Wellen ist die Belastung, die an jede Ende anwendbar ist, 2/3 des in der Tabelle angegebenen Wertes unter der Bedingung, dass die Belastungen die selbe Stärke und Richtung aufweisen und dass sie in der selben Richtung wirken. Andernfalls ist das technische Büro zu befragen.

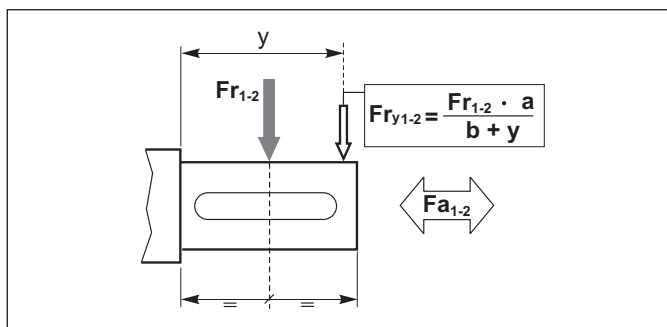

I carichi radiali indicati nelle tabelle si intendono applicati a metà della sporgenza dell'albero e sono riferiti ai riduttori operanti con fattore di servizio 1.

The radial loads indicated in the chart are considered to be applied at the half-way point of the shaft projection, and refer to gear units operating with service factor 1.

Die in den Tabellen angegebenen radialbelastungen gelten für Ansatzpunkte in der Mitte des herausragenden Wellenteils und für Getriebe mit Betriebsfaktor 1.

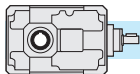

T 56B		T 63B		T 56C		T 63C	
ALBERO ENTRATA / INPUT SHAFT / ANTRIEBSWELLE ($n_1 = 1400 \text{ min}^{-1}$)							
in	a = *	b = *	a = *	b = *	in	a = *	b = *
	Fr ₁	Fa ₁	Fr ₁	Fa ₁		Fr ₁	Fa ₁
Tutti All Alle	*	*	*	*	Tutti All Alle	*	*

* Consultare il ns. Servizio Tecnico.

* Contact Tramec Technical dept..

* Fragen sie Tramec technisches Büro.

T 56B		T 63B		T 56C		T 63C	
ALBERO USCITA / OUTPUT SHAFT / ABTRIEBSWELLE ($n_1 = 1400 \text{ min}^{-1}$)							
in	a = 106	b = 81	a = 121	b = 93.5	in	a = 106	b = 81
	Fr ₂	Fa ₂	Fr ₂	Fa ₂		Fr ₂	Fa ₂
8	1300	260	1500	300	40	2300	460
10	1300	260	1500	300	50	2300	460
12.5	1300	260	1500	300	63	2300	460
16	1800	360	2000	400	80	2800	560
20	1800	360	2000	400	100	2800	560
25	1800	360	2000	400	125	2800	560
31.5	1800	360	2000	400	160	2800	560
40	2300	460	2500	500	200	3000	600
50	2300	460	2500	500	250	3000	600
63	—	—	2500	500	315	—	—

T 71B		T 90B		T 112B		T 140B		T 180B		T200B		T 225B		
ALBERO ENTRATA / INPUT SHAFT / ANTRIEBSWELLE ($n_1 = 1400 \text{ min}^{-1}$)														
in	a = 66.75	b = 51.75	a = 77	b = 57	a = 90	b = 70	a = 113	b = 83	a = 141.5	b = 101.5	a = 138.5	b = 98.5	a = 201	b = 146
	Fr ₁	Fa ₁	Fr ₁	Fa ₁	Fr ₁	Fa ₁	Fr ₁	Fa ₁	Fr ₁	Fa ₁	Fr ₁	Fa ₁	Fr ₁	Fa ₁
8-40	400	80	630	125	1000	200	1600	320	2500	500	2500	500	3150	630
50 80	400	80	630	125	1000	200	1600	320	2000	400	2000	400	3150	630
ALBERO USCITA / OUTPUT SHAFT / ABTRIEBSWELLE ($n_1 = 1400 \text{ min}^{-1}$)														
in	a = 114.5	b = 84.5	a = 131	b = 95	a = 161.5	b = 113.5	a = 192	b = 132	a = 236.5	b = 162	a = 276	b = 191	a = 325	b = 220
	Fr ₂	Fa ₂	Fr ₂	Fa ₂	Fr ₂	Fa ₂	Fr ₂	Fa ₂	Fr ₂	Fa ₂	Fr ₂	Fa ₂	Fr ₂	Fa ₂
8	—	—	—	—	—	—	—	—	—	—	25000	5000	36000	7200
10	3000	600	4750	950	7500	1500	11800	2360	19000	3800	26800	5360	38000	7600
12.5	3150	630	5000	1000	8000	1600	12500	2500	20000	4000	28800	5760	40000	8000
16	3350	670	5300	1060	8500	1700	13200	2640	21200	4240	30400	6080	42400	8480
20	3550	710	5600	1120	9000	1800	14000	2800	22400	4480	32200	6440	44800	8960
25	3750	750	6000	1200	9500	1900	15000	3000	23600	4720	34000	6800	47200	9440
31.5	4000	800	6300	1260	10000	2000	16000	3200	25000	5000	35800	7160	50000	10000
40	4250	850	6700	1340	10600	2120	17000	3400	26500	5300	37600	7520	53000	10600

T 80C		T 100C		T 125C		T 160C		T180C		T 200C		
ALBERO ENTRATA / INPUT SHAFT / ANTRIEBSWELLE ($n_1 = 1400 \text{ min}^{-1}$)												
in	a = 66.75	b = 51.75	a = 77	b = 57	a = 90	b = 70	a = 113	b = 83	a = 113	b = 83	a = 141.5	b = 101.5
	Fr ₁	Fa ₁	Fr ₁	Fa ₁	Fr ₁	Fa ₁	Fr ₁	Fa ₁	Fr ₁	Fa ₁	Fr ₁	Fa ₁
Tutti All Alle	400	80	630	125	1000	200	1600	320	2000	400	2500	500
ALBERO USCITA / OUTPUT SHAFT / ABTRIEBSWELLE ($n_1 = 1400 \text{ min}^{-1}$)												
in	a = 131	b = 95	a = 161.5	b = 113.5	a = 192	b = 132	a = 236.5	b = 162	a = 276	b = 191	a = 325	b = 220
	Fr ₂	Fa ₂	Fr ₂	Fa ₂	Fr ₂	Fa ₂	Fr ₂	Fa ₂	Fr ₂	Fa ₂	Fr ₂	Fa ₂
Tutti All Alle	8000	1600	12500	2500	20000	4000	32000	6400	43000	8600	53000	10600

Documento scaricabile dal sito: www.emporiodelcuscinetto.it

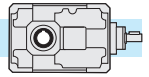

TA/TF 56B - TA/TF 63B

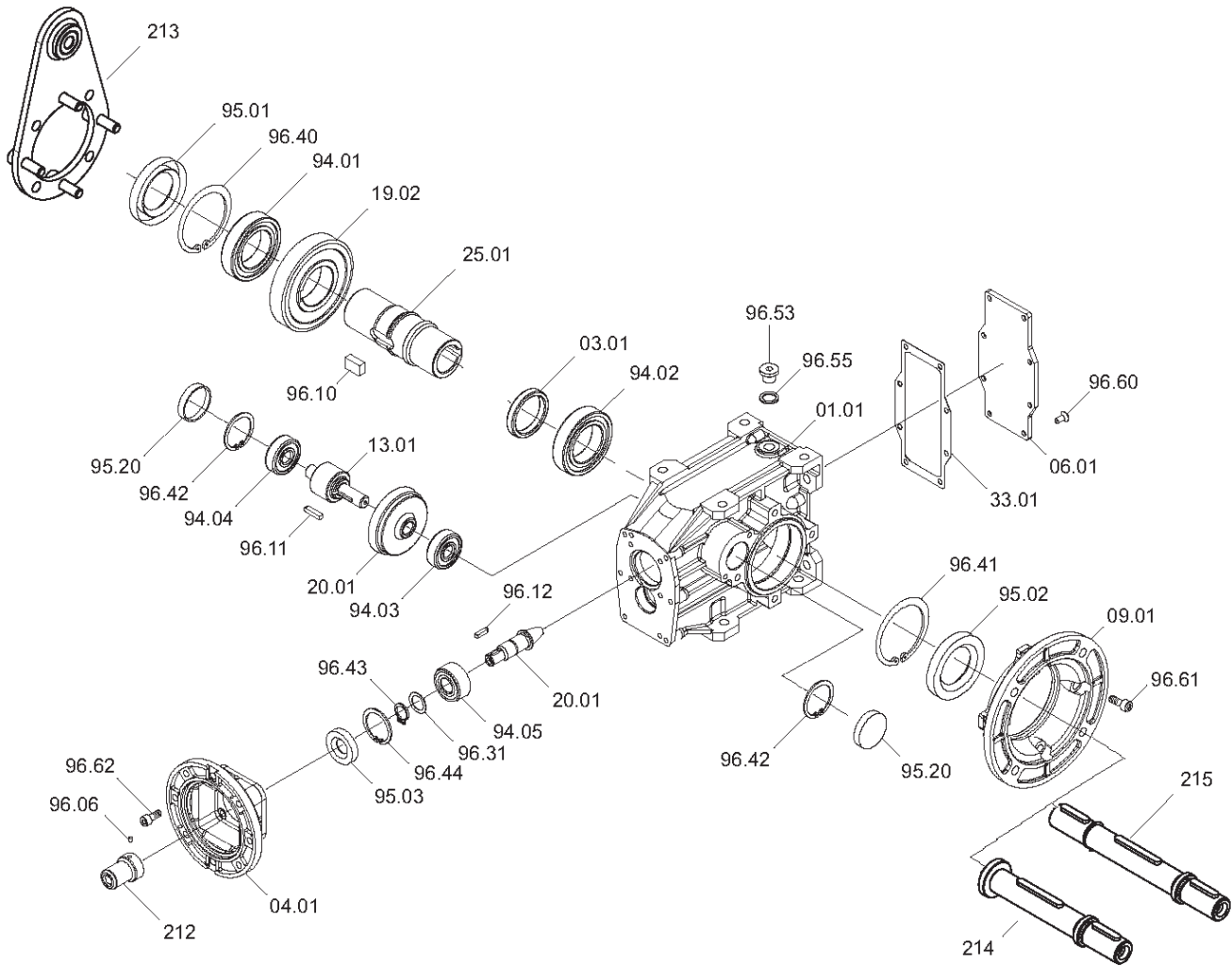

Documento scaricabile dal sito: www.emporiodelcuscinetto.it

T	Cuscinetti / Bearings / Lager					Anelli di tenuta / Oilseals / Öldichtungen		
	TA - TF					TA - TF		
	94.01	94.02	94.03	94.04	94.05	95.01	95.02	95.03
56B	6007 35/62/14	6007 35/62/14	6201 12/32/10	6201 12/32/10	3201 12/32/15.9	35/62/7	35/62/7	12/32/7
63B	6008 40/68/15	6008 40/68/15	6301 12/37/12	6301 12/37/12	3202 15/35/15.9	40/68/10	40/68/10	15/35/7

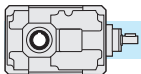

TA/TF 56C - TA/TF 63C

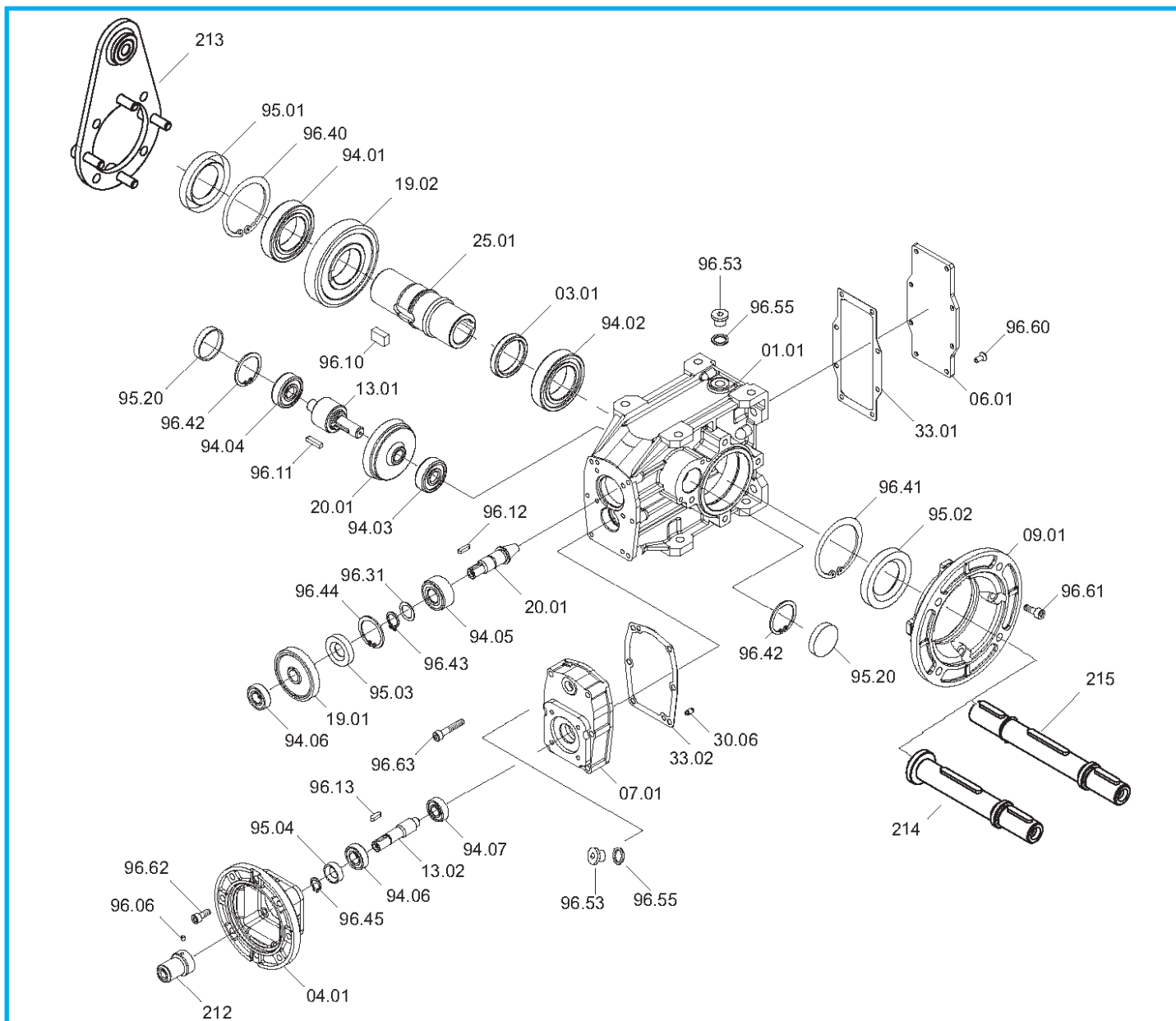

Documento scaricabile dal sito: www.emporiodelcuscinetto.it

T	Cuscinetti / Bearings / Lager							Anelli di tenuta / Oilseals / Öldichtungen			
	TA - TF							TA - TF			
	94.01	94.02	94.03	94.04	94.05	94.06	94.07	95.01	95.02	95.03	95.04
56C	6007 35/62/14	6007 35/62/14	6201 12/32/10	6201 12/32/10	3201 12/32/15.9	6001 12/28/8	6000 10/26/8	35/62/7	35/62/7	12/32/7	12/22/7
63C	6008 40/68/15	6008 40/68/15	6301 12/37/12	6301 12/37/12	3202 15/35/15.9	6001 12/28/8	6000 10/26/8	40/68/10	40/68/10	15/35/7	12/22/7

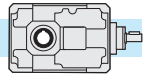

TA..B - TC..B - TF..B

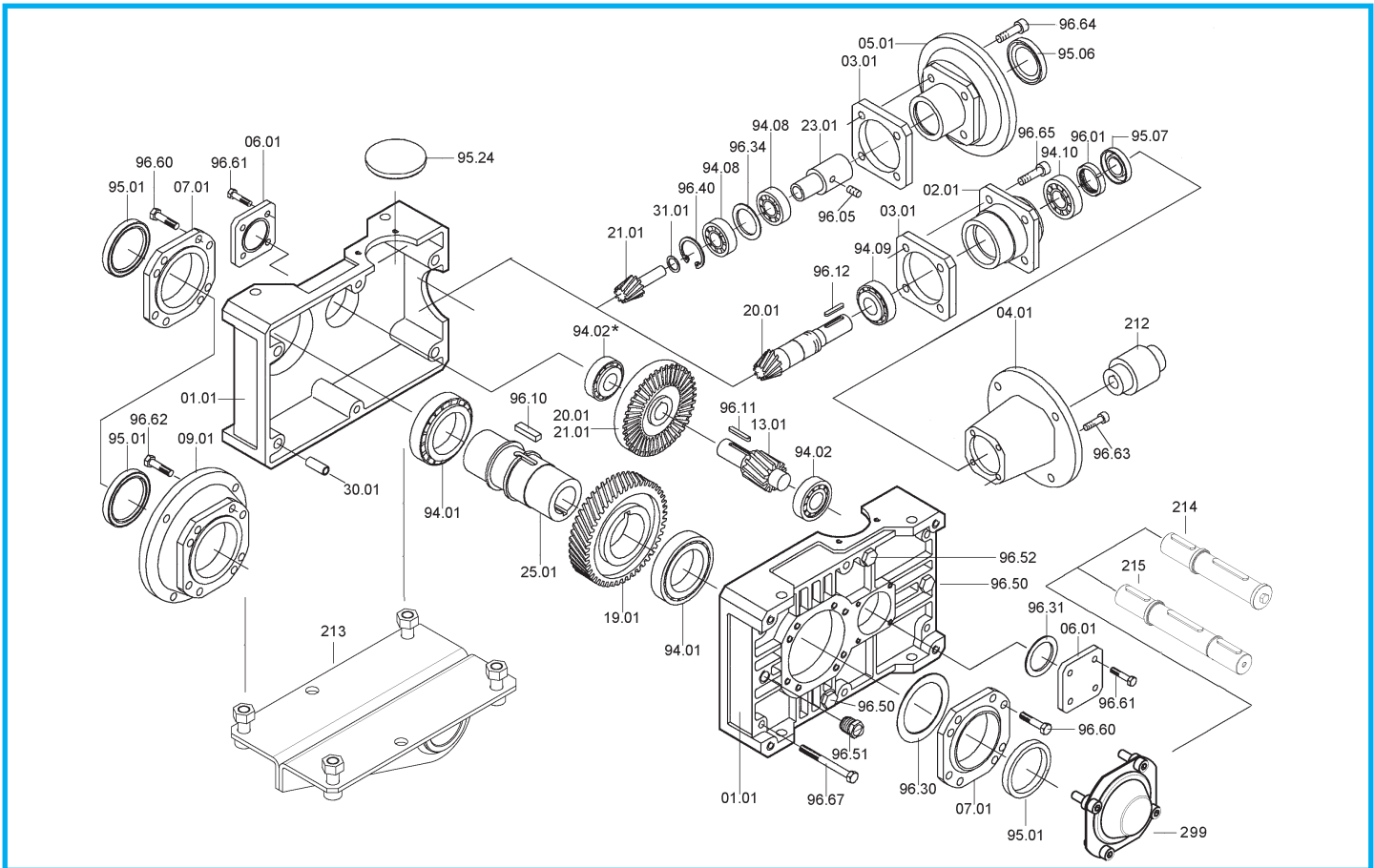

Documento scaricabile dal sito: www.emporiodelcuscinetto.it

T	Cuscinetti / Bearings / Lager					Anelli di tenuta / Oilseals / Öldichtungen				
	TA - TC - TF		TC	TA - TF		TA - TC - TF	TC	TA - TF		
	94.01	94.02	94.08	94.09	94.10	95.01	IEC	95.06	95.07	
71B	32008 40/68/19	30302 15/42/14.25	7203 17/40/12	30203 17/40/13.25		40/56/8	63	25/52/7	15/40/10	
							71	30/52/7		
							80	35/52/7		
							90	37/52/8		
90B	32010 50/80/20	30204 20/47/15.25	7205 25/52/15	32005 25/47/15		50/65/8	71 - 80	35/62/7	20/47/7	
							90	40/62/7		
							100 - 112	45/62/8		
							80 - 90	40/72/7		
112B	32012 60/95/23	30305 25/62/18.25	7206 30/62/16	32006 30/55/17		60/80/10	100 - 112	45/72/8	25/58/10	
							132	55/72/10		
							80 - 90	45/80/10		
							100 - 112	45/80/10		
140B	32015 75/115/25	32206B 30/62/21.25	7207 35/72/17	32007 35/62/18		75/95/10	132	55/80/10	30/62/7	
							160	60/80/8		
							180	65/80/8		
							100 - 112	55/100/13		
180B	32019 95/145/32	31307 / (32208)* 35/80/22.75 / (40/80/24.75)*	7209 45/85/19	32009 45/75/20		95/125/12	132 - 160	60/100/10	40/80/10	
							180	65/100/10		
							200	75/100/10		
							100 - 112	55/100/13		
200B	32024 120/180/38	31309 45/100/27.25	7209 45/85/19	33109 45/80/26		120/160/15	132 - 160	60/100/10	40/80/10	
							180	65/100/10		
							200	75/100/10		
							100 - 112	55/100/13		
225B	32026 130/200/45	31310 50/110/29.25	—	33111 55/95/30	32011 55/90/23	130/160/12	—	—	50/90/10	

* Presente solo nella versione con antiretro / Only on version with back stop device / Nur auf Version mit Rücklaufperre

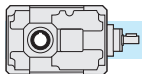

2.15 Lista parti di ricambio

2.15 Spare parts list

2.15 Ersatzteilliste

TA..C - TC..C - TF..C

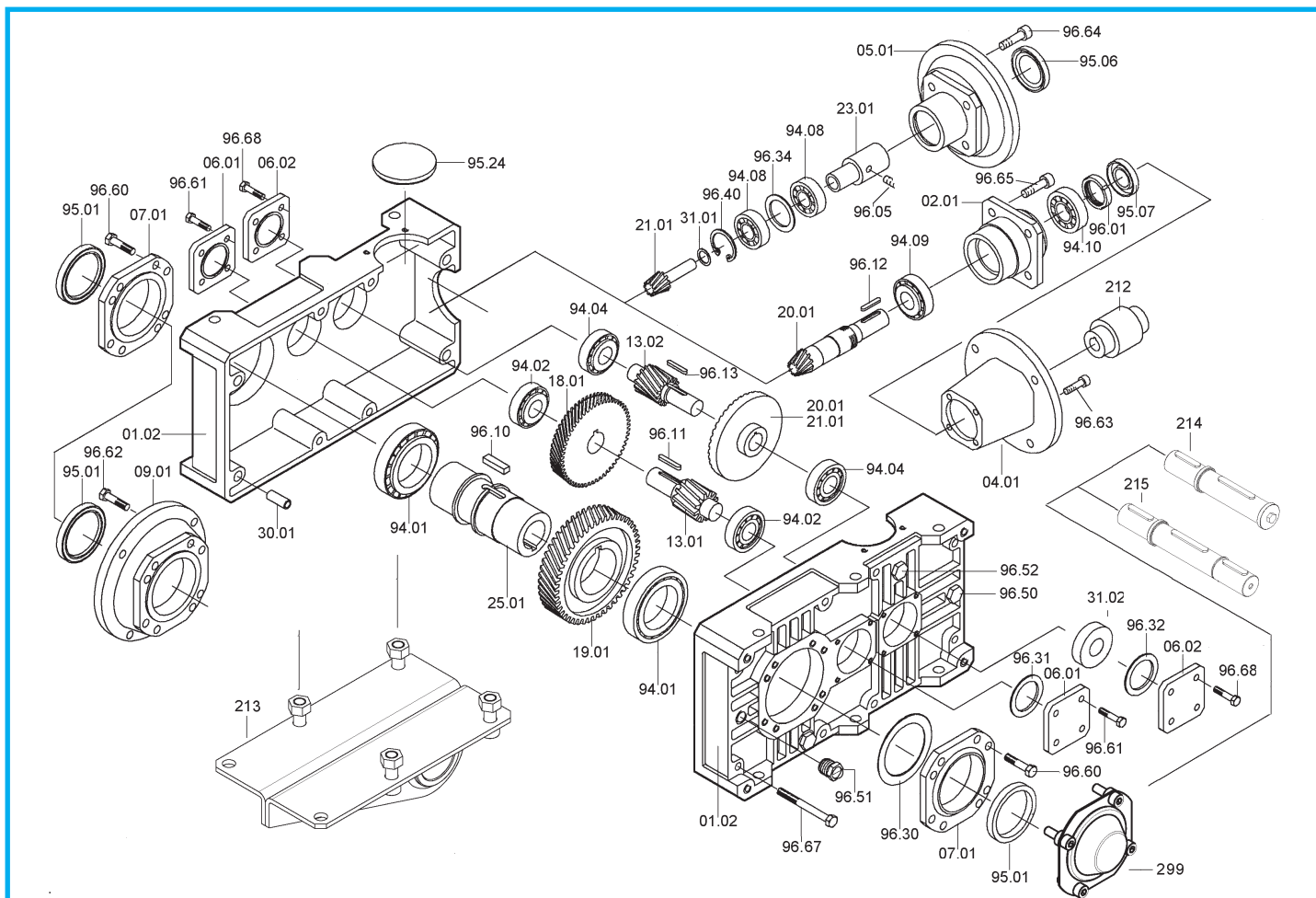

Documento scaricabile dal sito: www.emporiodelcuscinetto.it

T	Cuscinetti / Bearings / Lager					Anelli di tenuta / Oilseals / Öldichtungen				
	TA - TC - TF		TC	TA - TF		TA - TC - TF	TC	TA - TF		
	94.01	94.02	94.04	94.08	94.09	94.10	95.01	IEC	95.06	95.07
80C	32010 50/80/20	30204 20/47/15.25	30302 15/42/14.25	7203 17/40/12	32003 17/40/13.25		50/65/8	63	25/52/7	15/40/10
								71	30/52/7	
								80	35/52/7	
								90	37/52/8	
100C	32012 60/95/23	30305 25/62/18.25	30204 20/47/15.25	7205 25/52/15	32005 25/47/15		60/80/10	71 - 80	35/62/7	20/47/7
								90	40/62/7	
								100 - 112	45/62/8	
125C	32015 75/115/25	32206 30/62/21.25	30305 25/62/18.25	7206 30/62/16	32006 30/55/17		75/95/10	80 - 90	40/72/7	25/58/10
								100 - 112	45/72/8	
								132	55/72/10	
								80 - 90	45/80/10	
160C	32019 95/145/32	32207 35/72/24.25	32206 30/62/21.25	7207 35/72/17	32007 35/62/18		95/125/12	100 - 112	45/80/10	30/62/7
								132	55/80/10	
								160	60/80/8	
								180	65/80/8	
180C	32024 120/180/38	31309 45/100/27.25	32206 30/62/21.25	7207 35/72/17	32007 35/62/18		120/160/15	80 - 90	45/80/13	30/62/7
								100 - 112	45/80/10	
								132	55/80/10	
								160	60/80/10	
200C	32026 130/200/45	31310 50/110/29.25	30307 35/80/22.75	7209 45/85/38	32009 45/75/20		130/160/12	180	65/100/10	40/80/10
								100 - 112	55/100/13	
								132 - 160	60/100/10	
								200	75/100/10	

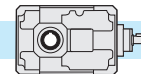

TA..B - TC..B - TF..B - TA..C - TC..C - TF..C

Dispositivo antiritorno - Backstop device - Rücklaufperre

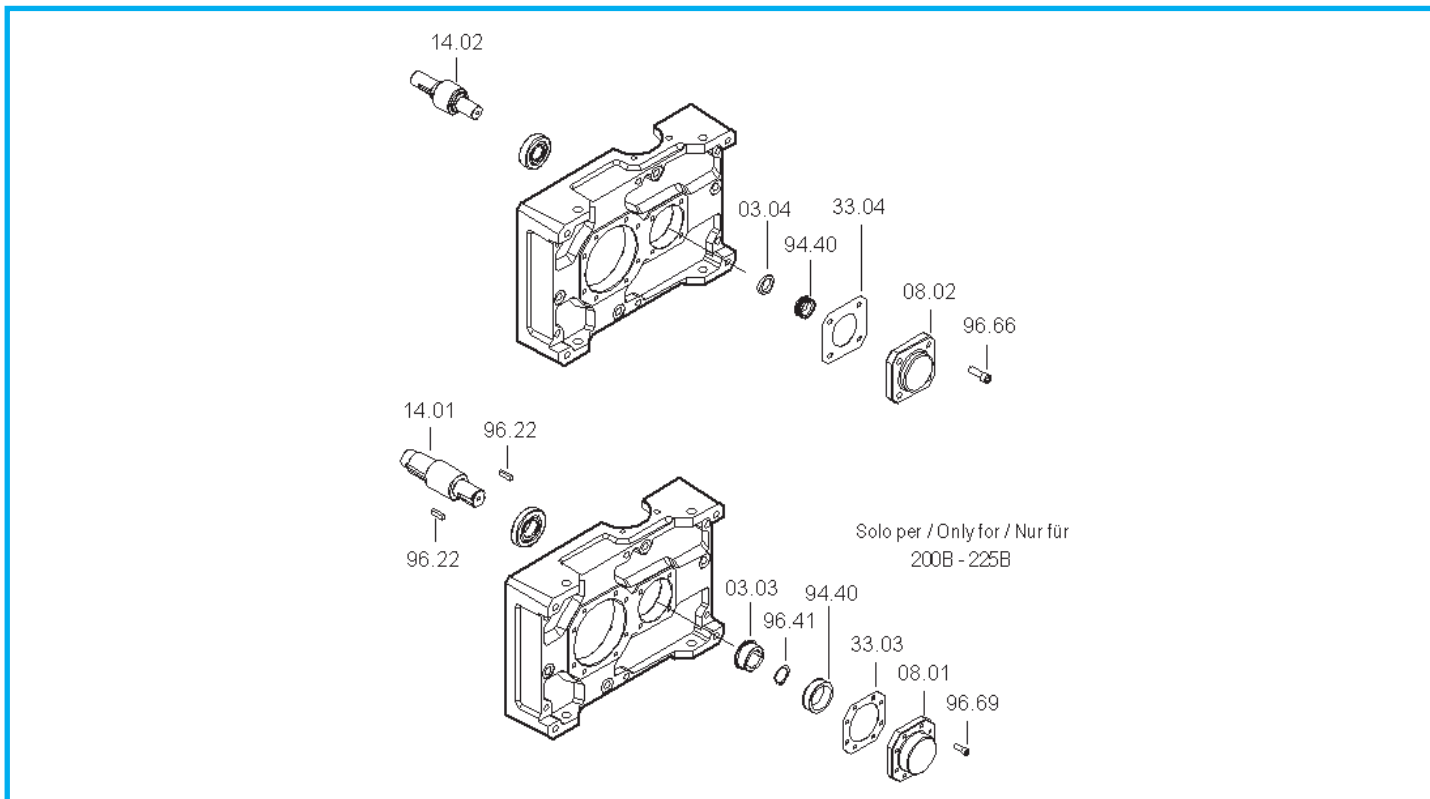

T...B	Ruota libera / Free wheel / Freilauftrad 94.40
71	FE 423 Z
90	FE 428 Z
112	BF 50 Z 16
140	BF 70 Z 21
180	FE 8040 Z 19
200	FE 8054 Z 25
225	FE 8072 Z 25

T...C	Ruota libera / Free wheel / Freilauftrad 94.40
80	FE 423 Z
100	FE 428 Z
125	BF 50 Z 16
160	BF 70 Z 21
180	BF 70 Z 21
200	FE 8040 Z 19

In fase di ordine delle parti di ricambio, specificare sempre n° particolare (vedi disegno esploso), data (1), n° codice (2) e n° variante (3).
(Vedi targhetta).

When ordering a spare part, the spare part number (see exploded technical drawing), the date (1), the code number (2) and the variant number (3) should always be reported.
(See plate)

Bei der Bestellung von Ersatzteilen sind Ersatzteilnummer (s. Explosionszeichnung), Datum (1), Artikelnummer (2) und Variantennummer (3) anzugeben.
(s. Schild)

TIPO: descrizione
TYPE: description
TYP: Bezeichnung

RAP: rapporto di riduzione
RATIO: reduction ratio
ÜBERS.: Untersetzungsverhältnis

Codice prodotto
Article code
ART.-Nr.

TIPO	TYPE	RAP. RATIO
		DATA DATE
CODICE N°	CODE N°	
TRAMEC		BOLOGNA ITALY

DATA: mese/anno
DATE: month/year
DATUM: Monat/Jahr

VARIANTE: codice alfanumerico
VARIANT: alphanumeric code
VARIANTE: alphanumerische Nummer

