

**emporio del
cuscinetto s.r.l.**

forniture industriali

CATALOGO GUIDE LINEARI A RICIRCOLO DI SFERE IN MINIATURA

12.4 Miniature Type, MSC \ MSD Stainless Steel Series

A. Construction

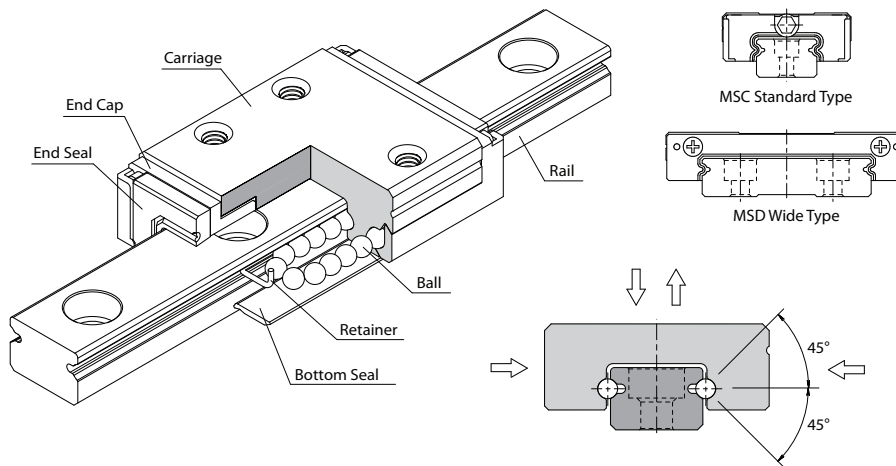

B. Characteristics

MSC st ows with Gothic-arch groove and designed to contact angle of 45° which enables it to bear an equal load in radial, reversed radial and lateral directions. Furthermore, ultra compact and low friction resistance design is suit to compact equipment. The lubrication route makes the lubricant evenly distribute in each circulation loop. Therefore, the optimum lubrication can be achieved in any installation direction, and this promotes the performance in running accuracy, service life, and reliability.

B102

Per informazioni: info@emporiodelcuscinetto.it - Tel. 049.896.1481

Four-way Equal Load

The two trains of balls are allocated to a Gothic-arch groove contact angle at 45°, thus each train of balls can take up an equal rated load in all four directions.

Ultra Compact

The ultra compact design is suitable for compact applications with limited space.

Ball Retainer

Design with ball retainers can prevent balls from dropping.

Smooth Movement with Low Noise

The simplified design of the circulating system with strengthened synthetic resin accessories makes the movement smooth and quiet.

Interchangeability

For interchangeable types of linear guideway, the dimensional tolerances are strictly maintained within a reasonable range, and this has made the random matching of the same size of rails and carriages possible. Therefore, similar preload and accuracy can be obtained even under random matching conditions. As a result of this advantage, the linear guideway can be stocked as standard parts, and installation and maintenance become more convenient. Moreover, this is also beneficial for shortening the delivery time.

C. Description of Specification

(1) Non-interchangeable Type

	MSC	7	M	2	LL	F0	
Series : MSC, MSD							
Size : 7, 9, 12, 15							
Carriage type : M : Standard type (Stainless) LM : Heavy load type (Stainless)							
Number of carriages per rail : 1, 2, 3 ...							
Dust protection option of carriage : LL, RR (refer to chapter 15.1 Dust Proof)							
Preload : FZ (Clearance), FC (Light preload), F0 (Medium preload)							
Code of special carriage : No symbol, A, B, C, D ...							
Rail type : R (Counter bore type)							
Rail length (mm)							
Rail hole pitch from start side (E1 , see Fig.12.4)							
Rail hole pitch to the end side (E2 , see Fig.12.4)							
Accuracy grade : N, H, P							
Stainless steel							
Code of special rail : No symbol, A, B ...							
Number of rails per axis : No symbol, II, III, IV ...							

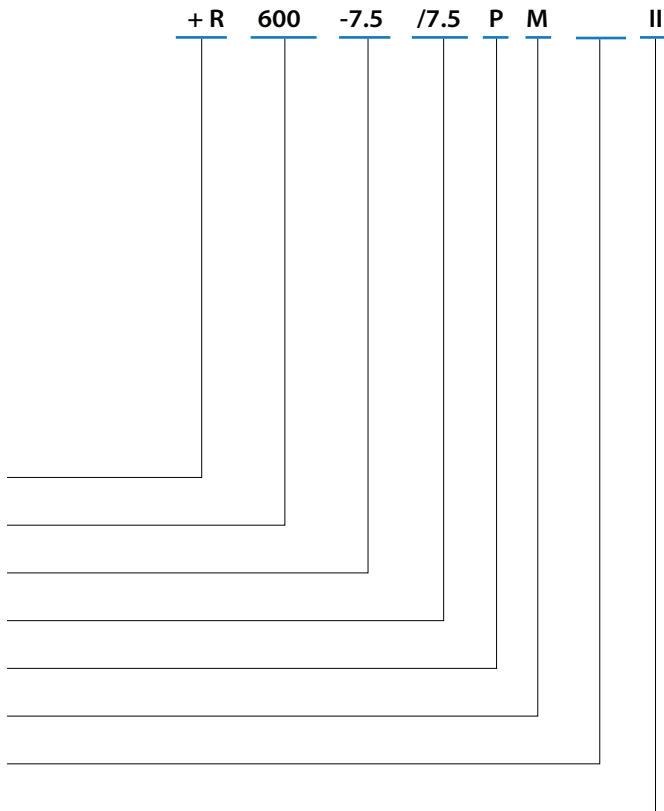
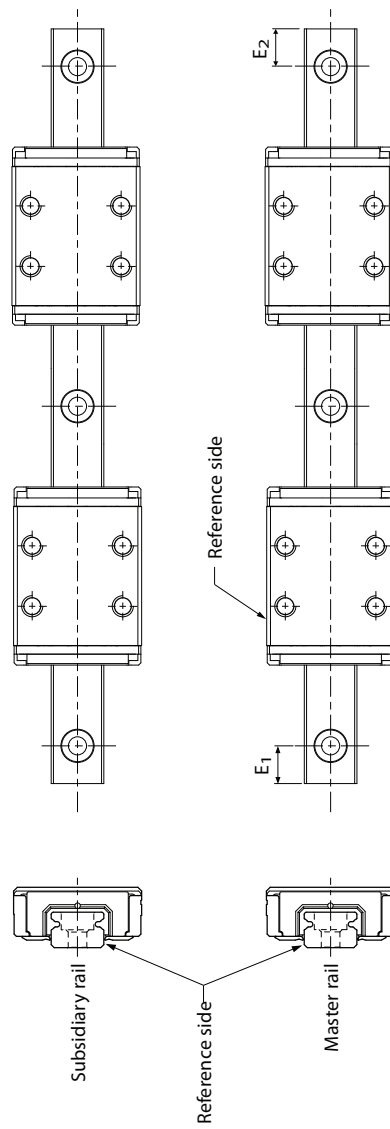
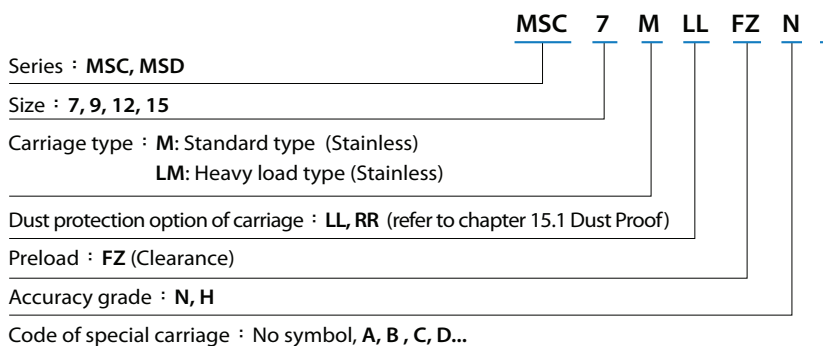

Fig 12.4



(2) Interchangeable Type

Code of Carriage



Code of Rail

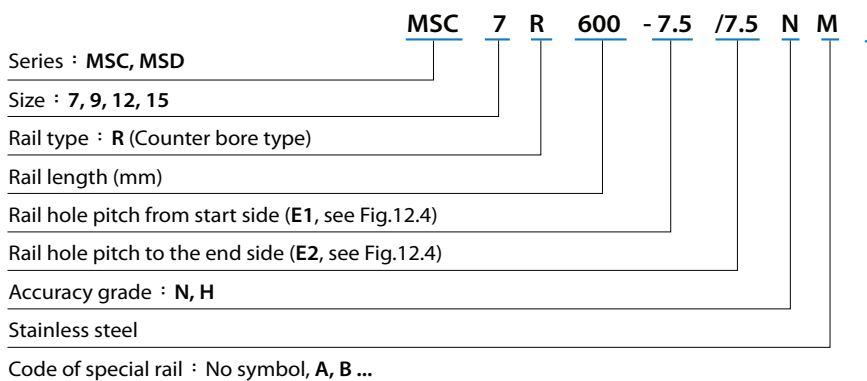

F. Accuracy Grade

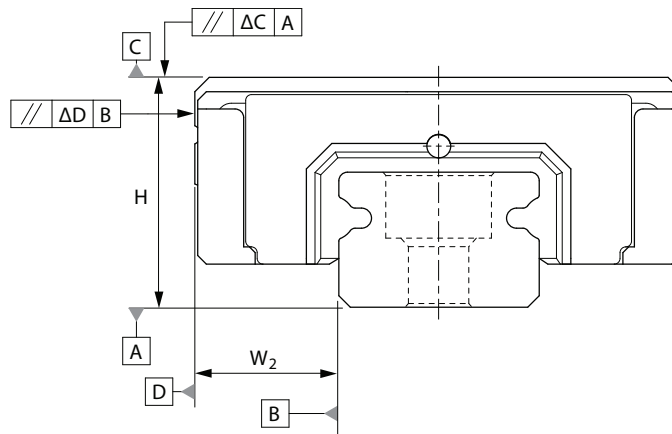

Table 1 Running Parallelism

Rail length (mm)		Running Parallelism Values (μm)		
Above	Or less	N	H	P
-	40	8	4	1
40	70	10	4	1
70	100	11	4	2
100	130	12	5	2
130	160	13	6	2
160	190	14	7	2
190	220	15	7	3
220	250	16	8	3
250	280	17	8	3

B108

Per informazioni: info@emporiodelcuscinetto.it - Tel. 049.896.1481

Rail length (mm)		Running Parallelism Values(μm)		
Above	Or less	N	H	P
280	310	17	9	3
310	340	18	9	3
340	370	18	10	3
370	400	19	10	3
400	430	20	11	4
430	460	20	12	4
460	490	21	12	4
490	520	21	12	4
520	550	22	12	4
550	580	22	13	4
580	610	22	13	4
610	640	22	13	4
640	670	23	13	4
670	700	23	13	5
700	730	23	14	5
730	760	23	14	5
760	790	23	14	5
790	820	23	14	5
820	850	24	14	5
850	880	24	15	5
880	910	24	15	5
910	940	24	15	5
940	970	24	15	5
970	1000	25	16	5

A Non-Interchangeable Type

Model No.	Item	Accuracy Grade		
		Normal N	High H	Precision P
7 9 12 15	Tolerance for height H	±0.04	±0.02	±0.01
	Height difference ΔH	0.03	0.015	0.007
	Tolerance for distance W_2	±0.04	±0.025	±0.015
	Difference in distance $W_2(\Delta W_2)$	0.03	0.02	0.01
	Running parallelism of surface C with surface A	ΔC (see the table 1)		
	Running parallelism of surface D with surface B	ΔD (see the table 1)		

B110

Per informazioni: info@emporiodelcuscinetto.it - Tel. 049.896.1481

B Interchangeable Type

Model No.	Item		Accuracy Grade	
			Normal N	High H
7 9 12 15	Tolerance for height H		±0.04	±0.02
	Tolerance for distance W_2		±0.04	±0.025
	Paired single-rail	Height difference (ΔH)	0.03	0.015
		Difference in distance $W_2(\Delta W_2)$	0.03	0.02
	Paired multiple-rail height difference (ΔH)		0.07	0.04
	Running parallelism of surface C with surface A		ΔC (see the table 1)	
	Running parallelism of surface D with surface B		ΔD (see the table 1)	

G. Preload Grade

Series	Preload grade		
	Clearance (FZ)	Light preload (FC)	Medium preload (F0)
MSC7	Clearance 4~10 μ m	0	0.01~0.02C
MSC9			
MSC12			
MSC15			
MSC7L	Clearance 4~10 μ m	0	0.01~0.02C
MSC9L			
MSC12L			
MSC15L			
MSD7	Clearance 4~10 μ m	0	0.01~0.02C
MSD9			
MSD12			
MSD15			
MSD7L	Clearance 4~10 μ m	0	0.01~0.02C
MSD9L			
MSD12L			
MSD15L			

Note: C is basic dynamic load rating in above table. Refer to the specification of products, please.

H. The Shoulder Height and Corner Radius for Installation

MSC series

Unit: mm

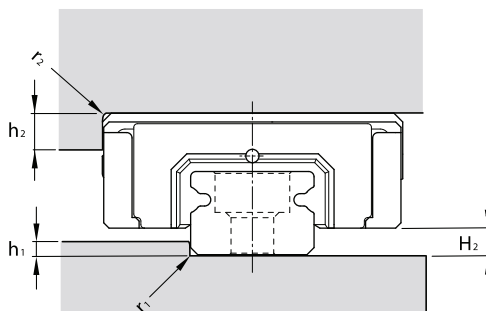

Model No.	r_1 (max.)	r_2 (max.)	h_1	h_2	H_2
7	0.2	0.2	1.0	3	1.5
9	0.2	0.3	1.7	3	2.2
12	0.3	0.4	2.5	4	3
15	0.5	0.5	3.5	5	4

B112

Per informazioni: info@emporiodelcuscinetto.it - Tel. 049.896.1481

MSD series

Unit: mm

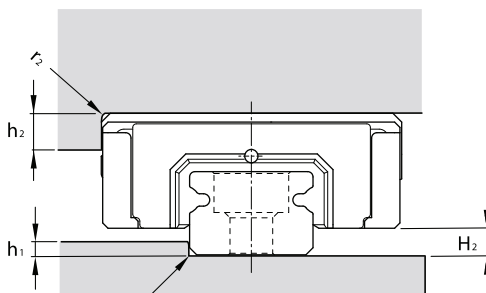

Model No.	r_1 (max.)	r_2 (max.)	h_1	h_2	H_2
7	0.2	0.2	1.5	3	2
9	0.2	0.3	3.2	3	3.7
12	0.3	0.4	3.5	4	4
15	0.5	0.5	3.5	5	4

I. Dimensional Tolerance of Mounting Surface

MSC \ MSD Series

The tolerances of parallelism between two axes are shown as below.

The parallel deviation between two axes (e_1)

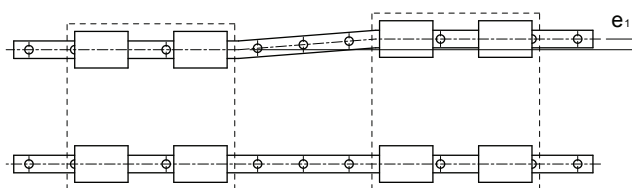

Unit: μm

Model No.	Preload Grade		
	FZ	FC	F0
MSC 7 MSD7	12	3	3
MSC 9 MSD9	15	4	3
MSC 12 MSD12	20	9	5
MSC 15 MSD15	25	10	6

Level difference between two axes (e_2)

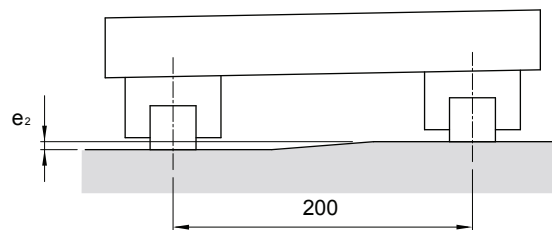

Unit: μm

Model No.	Preload Grade		
	FZ	FC	F0
MSC 7 MSD7	25	25	6
MSC 9 MSD9	35	35	6
MSC 12 MSD12	50	50	12
MSC 15 MSD15	60	60	20

Note: The permissible values in table are applicable when the span is 200mm wide.

B114

Per informazioni: info@emporiodelcuscinetto.it - Tel. 049.896.1481

J. Rail Maximum Length and Standrad

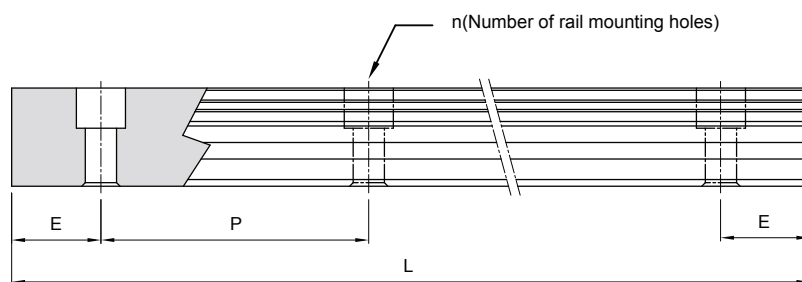

$$L = (n-1) \times P + 2 \times E$$

L : Total Length of rail (mm)

n : Nuber of mounting holes

P : Distance between any two holes (mm)

E : Distance from the center of the last hole to the edge (mm)

Unit: μm

Model No.		Standard Pitch (P)	Standard ($E_{std.}$)	Standard (maximum) ($L_0 \text{ max.}$)
MSC	7	15	5	1000
	9	20	7.5	1000 (2000)
	12	25	10	1000 (2000)
	15	40	15	1000 (2000)
MSD	7	30	10	1000 (2000)
	9	30	10	1000 (2000)
	12	40	15	1000 (2000)
	15	40	15	1000 (2000)

Dimensions of MSC-M / MSC-LM

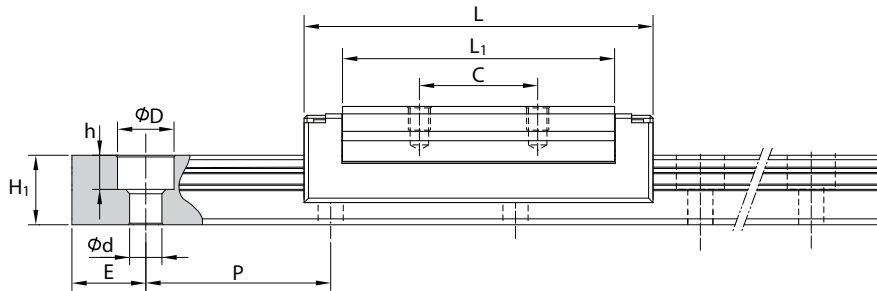

Unit: mm

Model No.	External dimension					Carriage dimension					
	Height H	Width W	Length L	W_2	H_2	B	C	$S \times \ell$	L_1	T	G
MSC 7 M MSC 7 LM	8	17	23.6 33.1	5	1.5	12	8 13	M2×2.5	18.4 27.9	3.5	Ø0.8
MSC 9 M MSC 9 LM	10	20	31.1 41.3	5.5	2.2	15	10 16	M3×3	25.8 36	4.5	Ø1
MSC 12 M MSC 12 LM	13	27	34.6 47.6	7.5	3	20	15 20	M3×3.6	28 41	6	Ø1.5
MSC 15 M MSC 15 LM	16	32	43.5 60.5	8.5	4	25	20 25	M3×4.2	36.1 53.1	7	G-M3

Note: The basic dynamic load rating C of ball type is based on the 50 km for nominal life. The conversion between C for 50 km and C_{100} for 100 km is $C=1.26 \times C_{100}$.

Note*: Single: Single carriage/ Double: Double carriages closely contacting with each other.

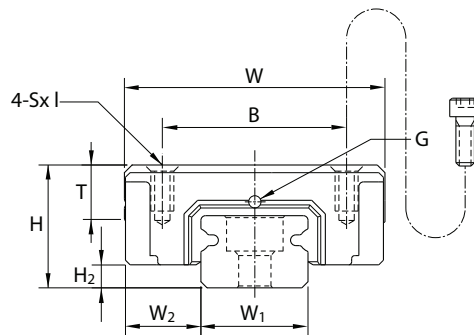
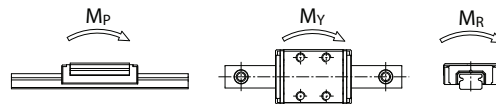

Unit: mm

Model No.	Rail dimension					Basic load rating		Static moment rating					Weight	
	Width W _i	Height H _i	Pitch P	E std.	D × h × d	Dynamic C kN	Static C ₀ kN	M _p N-m		M _y N-m		M _r N-m	Carriage kg	Rail kg/m
								Single*	Double*	Single*	Double*			
MSC 7 M MSC 7 LM	7 _{-0.05}	4.7	15	5	4.2×2.3×2.4	0.94 1.36	1.28 2.24	2.6 7.4	15.33 37.92	2.6 7.4	15.33 37.92	4.7 8.3	13 18	0.22
MSC 9 M MSC 9 LM	9 _{-0.05}	5.5	20	7.5	6×3.3×3.5	1.71 2.52	2.24 3.92	6.1 17.4	33.46 84.63	6.1 17.4	33.46 84.63	10.8 18.8	29 39	0.33
MSC 12 M MSC 12 LM	12 _{-0.05}	7.5	25	10	6×4.5×3.5	2.62 3.77	3.52 5.72	11.4 28.3	63.96 141.52	11.4 28.3	63.96 141.52	22.2 36.0	40 60	0.63
MSC 15 M MSC 15 LM	15 _{-0.05}	9.5	40	15	6×4.5×3.5	4.52 6.47	5.70 9.26	24.7 61.0	132.17 295.87	24.7 61.0	132.17 295.87	44.4 72.2	71 100	1.02

Dimensions of MSD-M / MSD-LM

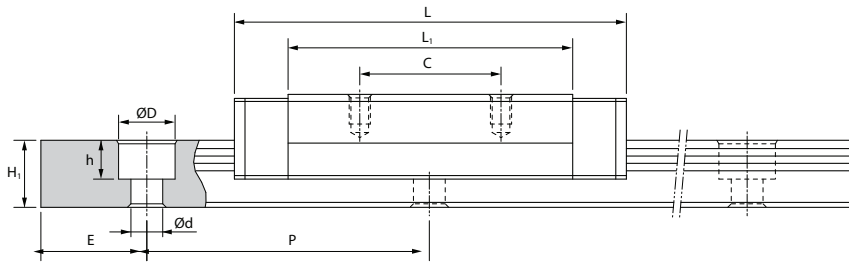

Unit: mm

Model No.	External dimension					Carriage dimension					
	Height H	Width W	Length L	W ₂	H ₂	B	C	S × l	L ₁	T	G
MSD 7 M MSD 7 LM	9	25	30.8 40.5	5.5	2	19	10 19	M3×3	20.6 30.3	3.9	Ø1.5
MSD 9 M MSD 9 LM	12	30	38.7 50.7	6	3.7	21 23	12 24	M3×3	27.1 39.1	5	Ø1.5
MSD 12 M MSD 12 LM	14	40	44.5 60	8	4	28	15 28	M3×4	31.0 46.5	6	Ø1.5
MSD 15 M MSD 15 LM	16	60	55.5 74.5	9	4	45	20 35	M4×4.5	40.3 59.3	7	Ø1.5

Note: The basic dynamic load rating C of ball type is based on the 50 km for nominal life. The conversion between C for 50 km and C100 for 100 km is $C=1.26 \times C100$.

Note*: Single: Single carriage/ Double: Double carriages closely contacting with each other.

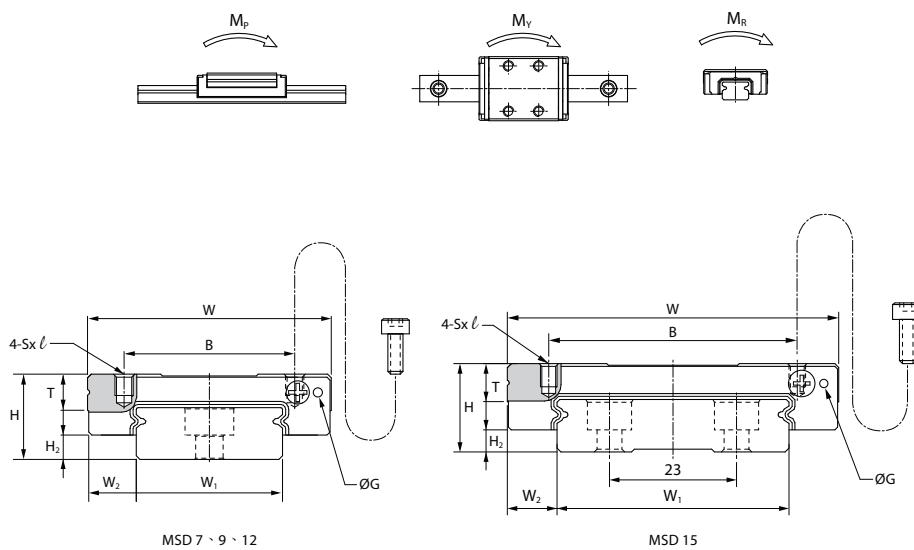

Unit: mm

Model No.	Rail dimension					Basic load rating		Static moment rating					Weight	
	Width W ₁	Height H ₁	Pitch P	E std.	D × h × d	Dynamic C kN	Static C ₀ kN	M _p N-m		M _V N-m		M _R N-m	Carriage kg	Rail kg/m
								Single*	Double*	Single*	Double*			
MSD 7 M MSD 7 LM	14 0 -0.05	5.2	30	10	6×3.2×3.5	1.51 2.04	2.46 3.79	6.6 17.5	39.0 84.0	6.6 17.5	39.0 84.0	17.7 27.3	23 31	0.55
MSD 9 M MSD 9 LM	18 0 -0.05	7	30	10	6×4.5×3.5	2.79 3.64	4.37 6.39	15.6 33.8	90.3 175.2	15.6 33.8	90.3 175.2	40.7 59.5	41 57	0.96
MSD 12 M MSD 12 LM	24 0 -0.05	8.5	40	15	8×4.5×4.5	4.05 5.28	6.20 9.06	26.3 57.0	151.5 294.4	26.3 57.0	151.5 294.4	76.3 116.6	70 101	1.55
MSD 15 M MSD 15 LM	42 0 -0.05	9.5	40	15	8×4.5×4.5	7.08 9.40	10.18 15.26	62.5 135.2	301.4 616.1	62.5 135.2	301.4 616.1	216.9 325.3	150 126	2.99